

## STORING HWH LEVELING JACKS

A topic that sometimes comes up concerns the proper method to store your hydraulic jacks for travel. In some instances the “JACKS DOWN” warning light or buzzer will come on, suggesting that your jacks may have extended while you’ve been driving. When you stop to check them, the jacks may appear to be fully retracted. Going through the “STORE” procedure again will cancel the warning light and buzzer.

HWH Corporation, who supplies most of leveling systems, recognized this condition as worthy of a service bulletin to their dealers. More recently they have issued a reminder which is specific to their 310 and 610 series touch panel systems. Following are both their original bulletin and excerpts from the more recent model-specific one. For more details, you may access HWH Corporation by phone or at their website: [www.hwhcorp.com](http://www.hwhcorp.com).

### 310 SERIES MANUAL TOUCH PANEL SYSTEM

310 Touch Panel has a NOT IN PARK/BRAKE light. To retract the jacks the ignition must be in “ACC” or “ON” position.

**NOTE: The jacks can be retracted with the ignition in the ACC position to avoid the warning buzzer while the jacks are retracting.**

Push the “ON” button. The ON light will come on. Push the “STORE” button. The STORE light will come on. The jacks will retract. The system will turn itself off 2 minutes after the last red Warning Light goes out. Pushing the “OFF” button or moving the ignition key will turn the STORE procedure off. This will allow thermal expansion to cause a jack to extend slightly. If the STORE procedure is interrupted, the system should be turned on, push the “STORE” button and allow the STORE procedure to be completed.

If a red Warning Light and/or buzzer comes on while traveling, push the “ON” button then the “STORE” button. The park brake does not need to be set.

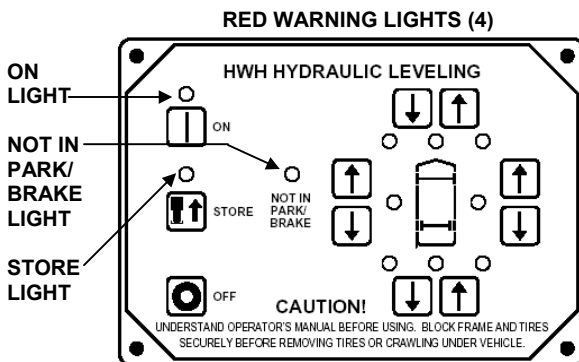

### 610 SERIES COMPUTERIZED TOUCH PANEL SYSTEM

The 610 pump and solenoid valve manifold is separate from the electronic controls.

To retract the jacks the ignition must be in the “ACC” or “ON” position.

**NOTE: The jacks can be retracted with the ignition in the ACC position to avoid the warning buzzer while the jacks are retracting.**

Push the “ON” button. The ON light will come on. Push the “STORE” button. The STORE light will flash. The jacks will retract. Six minutes after the last red Warning Light goes out, the Touch Panel will turn off. Pushing the “OFF” button or moving the ignition key will turn the STORE procedure off. This will allow thermal expansion to cause a jack to extend slightly. If the STORE procedure is interrupted, turn the system ON, push the STORE button and allow the STORE procedure to be completed.

If a Warning Light and/or buzzer comes on while traveling, push the “ON” button then the “STORE” button. The park brake does not have to be set.

**NOTE: Systems sold prior to 2002 will need the park brake set to put the system in the “STORE” mode. The vehicle should be stopped when safe to do so. Set the park brake. Leave the engine running. Push the “ON” button then the “STORE” button. It is OK to proceed when the jacks are retracted. The system will remain in the STORE mode when the park brake is released. The system will shut itself off six minutes after all 4 red Warning Lights have gone out.**

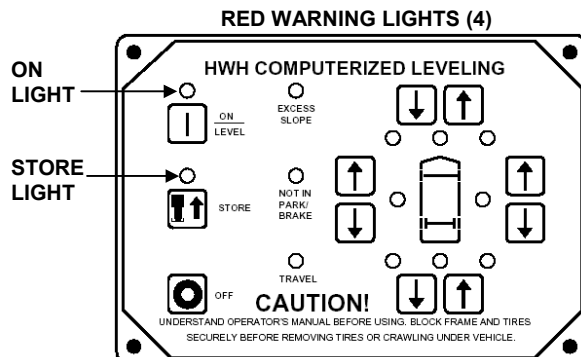



(On I-80, Exit 267 South) 2096 Moscow Road, Moscow, Iowa 52760

Phone: (800)321-3494 or (563)724-3396 Fax: (563)724-3408 Internet: www.hwhcorp.com

## PRODUCT/SERVICE BULLETIN

**ISSUE DATE:** March 16, 2001

**TO:** Sales and Service Personal

**FROM:** HWH CORPORATION

**RE:** Jacks down Warning Light and Buzzer

A complaint received by many service people is that the "JACKS DOWN" warning light and buzzer will come ON while traveling. This seems to happen more often in the first hour of traveling.

This is very often misdiagnosed as an electrical problem with the CONTROL BOX or WARNING SWITCH on the jack. Sometimes the jack cylinder is changed.

The most common cause of this problem is OPERATOR ERROR. The LEVELING SYSTEM is turned OFF while the "STORE" light on the touch panel is still ON. This happens with any 310 or 610 series leveling systems. The jacks are then left partially extended even though the warning lights have gone out.

The 310 systems will automatically turn OFF two minutes after the last red WARNING light on the touch panel goes out. The 610 systems will automatically turn OFF six minutes after the last red WARNING light on the touch panel goes out.

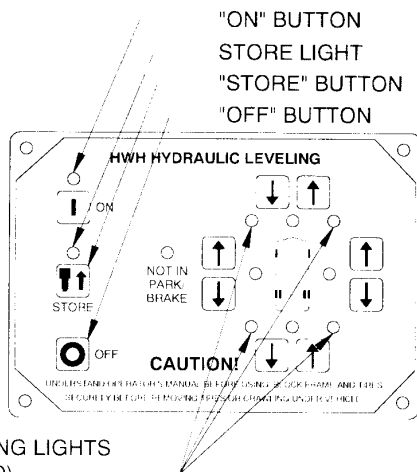

WARNING LIGHTS  
(4 - RED)

When a jack is retracting its red WARNING light will go out when a magnet in the jack opens the warning switch as it gets close to the switch. A jack will be extended at least 1 inch when the warning light goes out and will continue to retract until the solenoid valve closes. When the system is turned OFF, the solenoid valves for the jacks close. This locks the fluid in the jacks and the hoses. As a vehicle travels the temperature under the vehicle will increase, this can cause THERMAL EXPANSION of the fluid in the leveling system making one or more jacks extend slightly. If the jack is not fully retracted, thermal expansion of the fluid can extend the jack far enough to turn the MASTER WARNING light and buzzer ON.

Please contact HWH CORPORATION at 1-800-321-3494 for technical advice or assistance.

The leveling system must be allowed to complete the STORE cycle to keep this from happening. Pushing the "OFF" button or turning the ignition key while the STORE light is ON will interrupt the STORE cycle closing the solenoid valves. This will usually result in the MASTER WARNING light and buzzer coming ON.

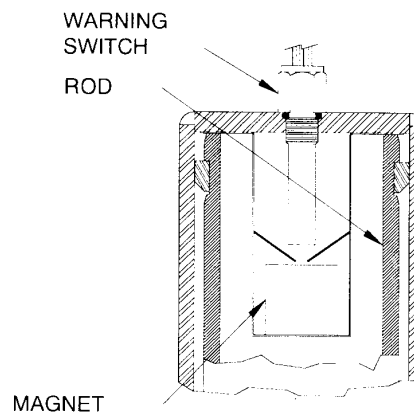

If a customer complains of this problem, level the vehicle then have him/her show you how he/she operates the system to store the jacks. Explain the importance of not interrupting the STORE cycle. Review the owners manual with the customer. It explains how to properly STORE the jacks and points out that the system should not be interrupted during the STORE cycle.

If it is evident that the operator is using the correct procedures for storing the jacks. Then the system should be checked for a possible problem. Take an ACCURATE measurement of each jack to see how far it extends before the WARNING light comes on. A problem with the jack may not let it fully retract. If a jack will not fully retract, the cylinder should be replaced. If the jack fully retracts, but extends less than one inch before the WARNING light comes on, replace the warning switch. If the jack is retracting fully and the warning switch is working properly, there may be an excessive heat problem somewhere on the system. Make sure hoses are not routed near heat sources, between frame rails on front engine vehicles, over transmission cross members or anywhere excessive heat may build up. Make sure a jack is not in an enclosed area where lack of air movement may allow excessive heat build up.

**200 Series Joystick:** This should never be a problem as long as the STORE LEVERS are in the STORE position, pulled to the center with the Joystick lever.

MI95.400C  
02MAY01