



DANGER

Danger of electrical shock, burns or death. Always remove all power sources before attempting any repair, service or diagnostic work. Power can be present from shore power, generator, inverter or battery. All power sources must be disabled and secured before performing any service.



CAUTION

If you lack the skills, tools or equipment to perform diagnostic or repair work leave such work to an authorized Winnebago Industries dealer or other qualified shop.

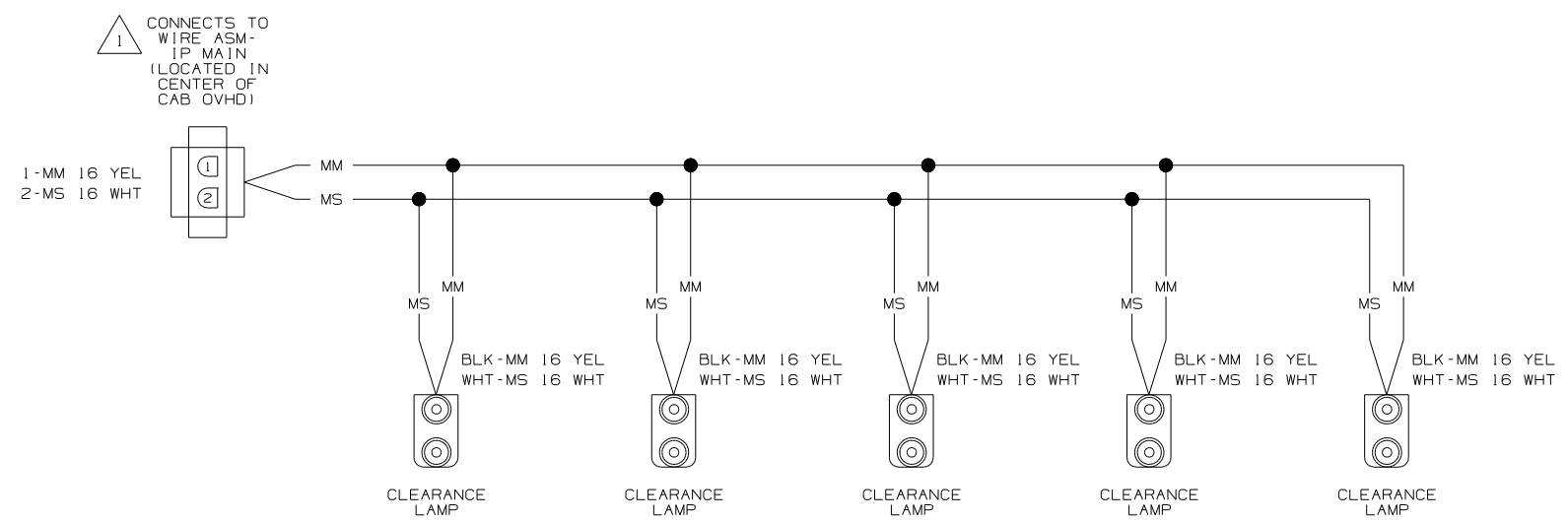
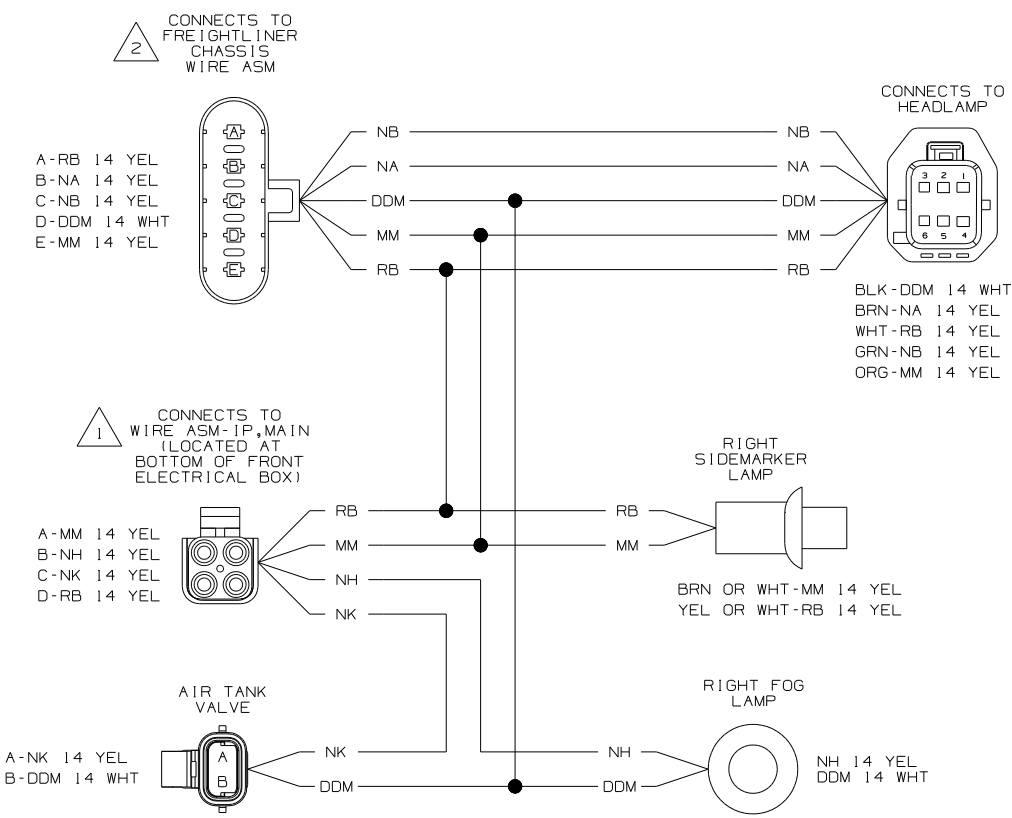
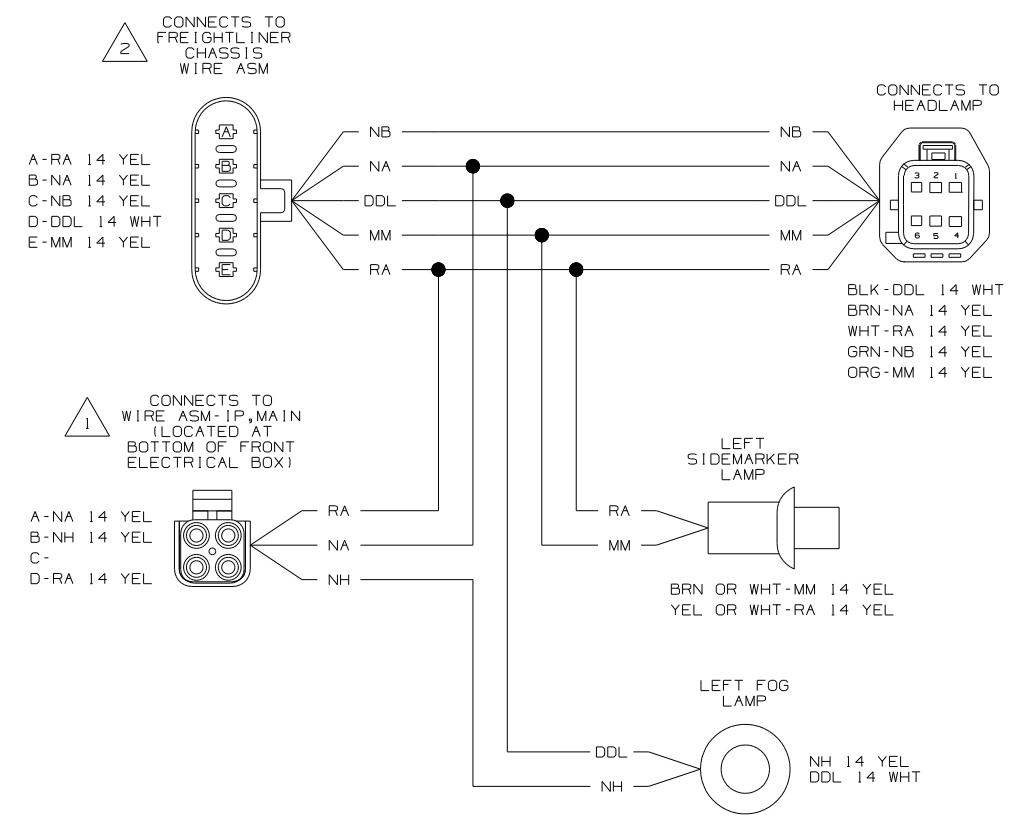

NOTES:

2 SEE MANUFACTURER'S DIAGRAM FOR ADDITIONAL INFORMATION.

1 SEE WIRING DIAGRAM AUTO FOR ADDITIONAL INFORMATION.

WINNEBAGO		COPYRIGHT 2006 WINNEBAGO INDUSTRIES, INC.	
DFTR	ORIG. DATE	ALL DIMENSIONS ARE IN MILLIMETERS	
CHKR		FIRST USED	
P.E.		07 S-SERIES	
M.E.		UNSPECIFIED TOLERANCES ARE:	
DSNR		MATERIAL:	
		WHOLE DIM (X)	:
		ONE-PLACE (X.X)	:
		TWO-PLACE (X.XX)	:
		ANGLE	:
		THIRD ANGLE PROJECTION	
DO NOT SCALE DRAWING			
TITLE: WIRING DIAGRAM-AUTO LAMPS			
SHEET 1 OF 3	PART NO	156379	REV
REF:	1 12/19/2006		

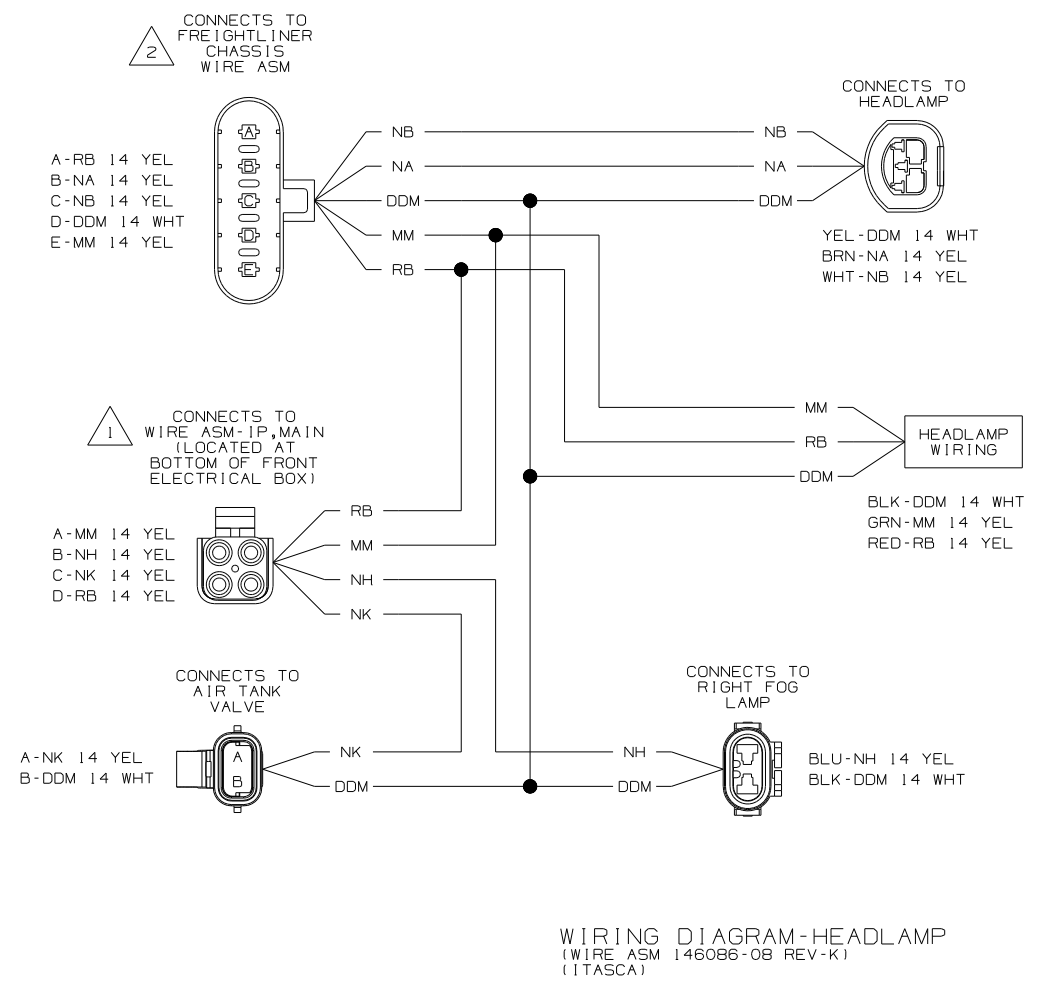
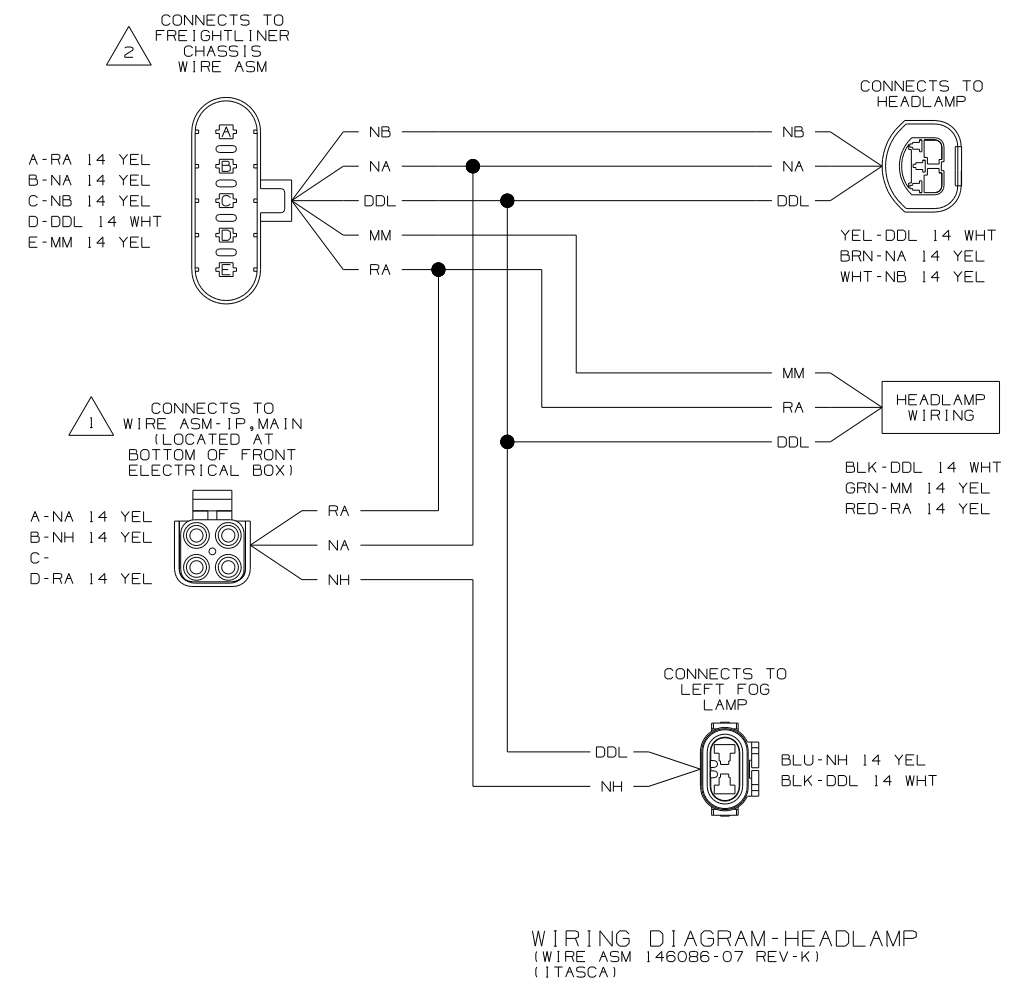

NOTES:
 2 SEE MANUFACTURER'S DIAGRAM FOR ADDITIONAL INFORMATION.
 1 SEE WIRING DIAGRAM AUTO FOR ADDITIONAL INFORMATION.

FIRST USED	07 S-SERIES	
TITLE	DO NOT SCALE DRAWING	
	WIRING DIAGRAM-AUTO LAMPS	
SHEET 2	PART NO 156379	REV

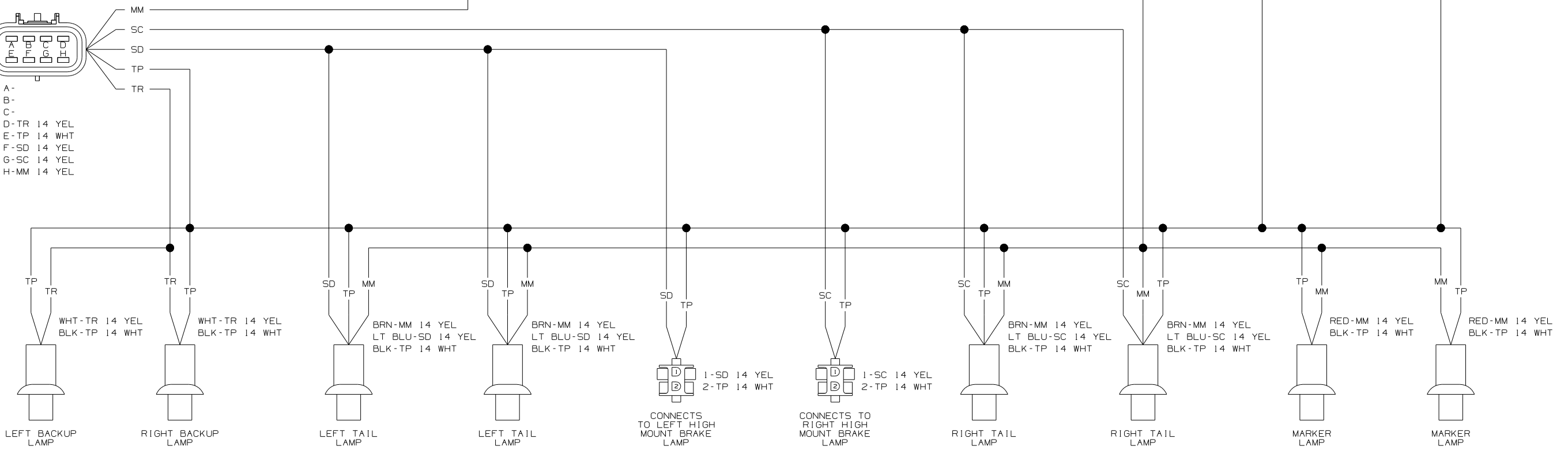
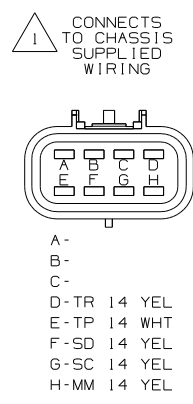
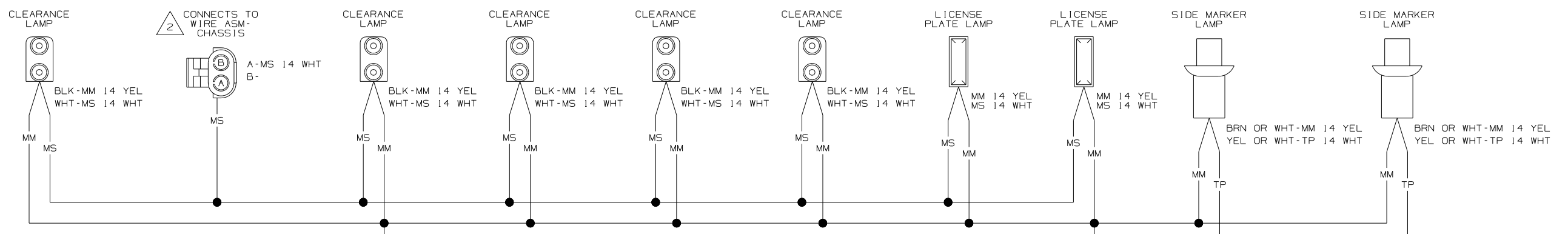

NOTES:

2 SEE WIRING DIAGRAM-BODY,12V FOR ADDITIONAL INFORMATION.

1 SEE MANUFACTURER'S DIAGRAM FOR ADDITIONAL INFORMATION.

WIRING DIAGRAM-BACKWALL,FL
(WIRE ASM 146221-06 REV-K1)

FIRST USED	07 S-SERIES
TITLE	DO NOT SCALE DRAWING
TITLE	WIRING DIAGRAM-AUTO LAMPS
SHEET 3	PART NO 156379 REV