



**DANGER**

**Danger of electrical shock, burns or death.** Always remove all power sources before attempting any repair, service or diagnostic work. Power can be present from shore power, generator, inverter or battery. All power sources must be disabled and secured before performing any service.



**CAUTION**

If you lack the skills, tools or equipment to perform diagnostic or repair work leave such work to an authorized Winnebago Industries dealer or other qualified shop.

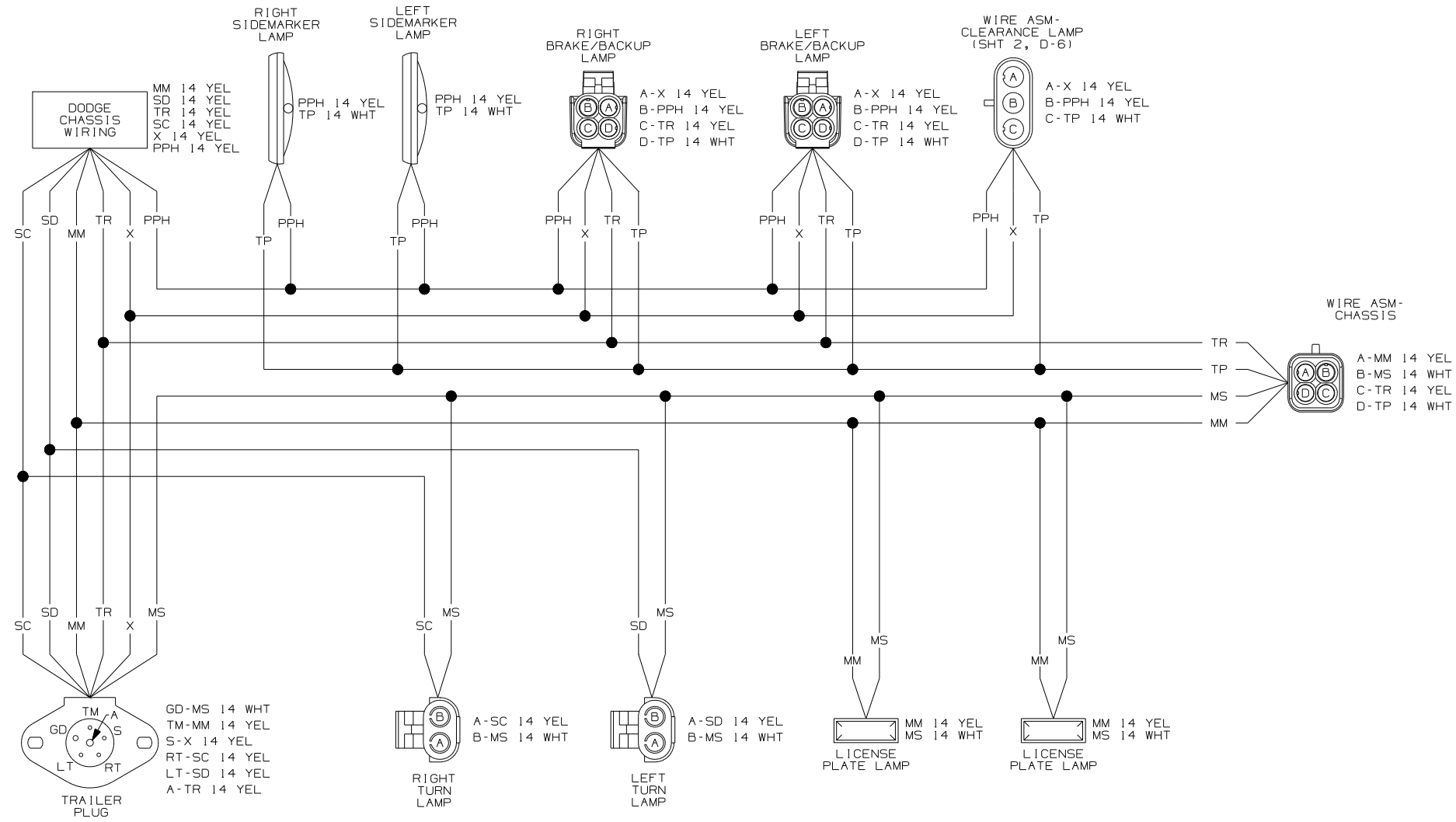

- 5 SEE WIRING DIAGRAM-AUTO FOR ADDITIONAL INFORMATION.
- 4 SEE MANUFACTURERS DIAGRAM FOR ADDITIONAL INFORMATION.
- 3 GROUNDS ARE SHOWN AS A SINGLE LINE FOR EASE IN TRACING. EACH GROUND CIRCUIT IS SEPERATE IN THE HARNESS.
- 2 NOT A SPLICE POINT. INDICATES ENTRY INTO WIRING HARNESS.

1. SPLICES ARE THEORETICAL AND MAY DIFFER IN THE HARNESS.

WIRE DIAGRAM-TAIL LAMPS  
(WIRE ASM 152165 REV-G)

<b>WINNEBAGO</b>		COPYRIGHT 2006 WINNEBAGO INDUSTRIES, INC.	
DFTR	ORIG. DATE		
CHKR	ALL DIMENSIONS ARE IN MILLIMETERS		
P.E.	FIRST USED	07 500-SER	
M.E.			
DSNR			
UNSPECIFIED TOLERANCES ARE:	MATERIAL:		
WHOLE DIM (X)	:	.	
ONE-PLACE (X.X)	:	.	
TWO-PLACE (X.XX)	:	.	
ANGLE	:	.	
THIRD ANGLE PROJECTION			
DO NOT SCALE DRAWING			
TITLE: WIRING DIAGRAM-AUOT LAMPS			
SHEET 1 OF 2	PART NO	156365	REV
REF:	1 6/16/2006		

CONNECTS TO WIRE ASM-TAIL LAMPS (SHT 1, D-3)

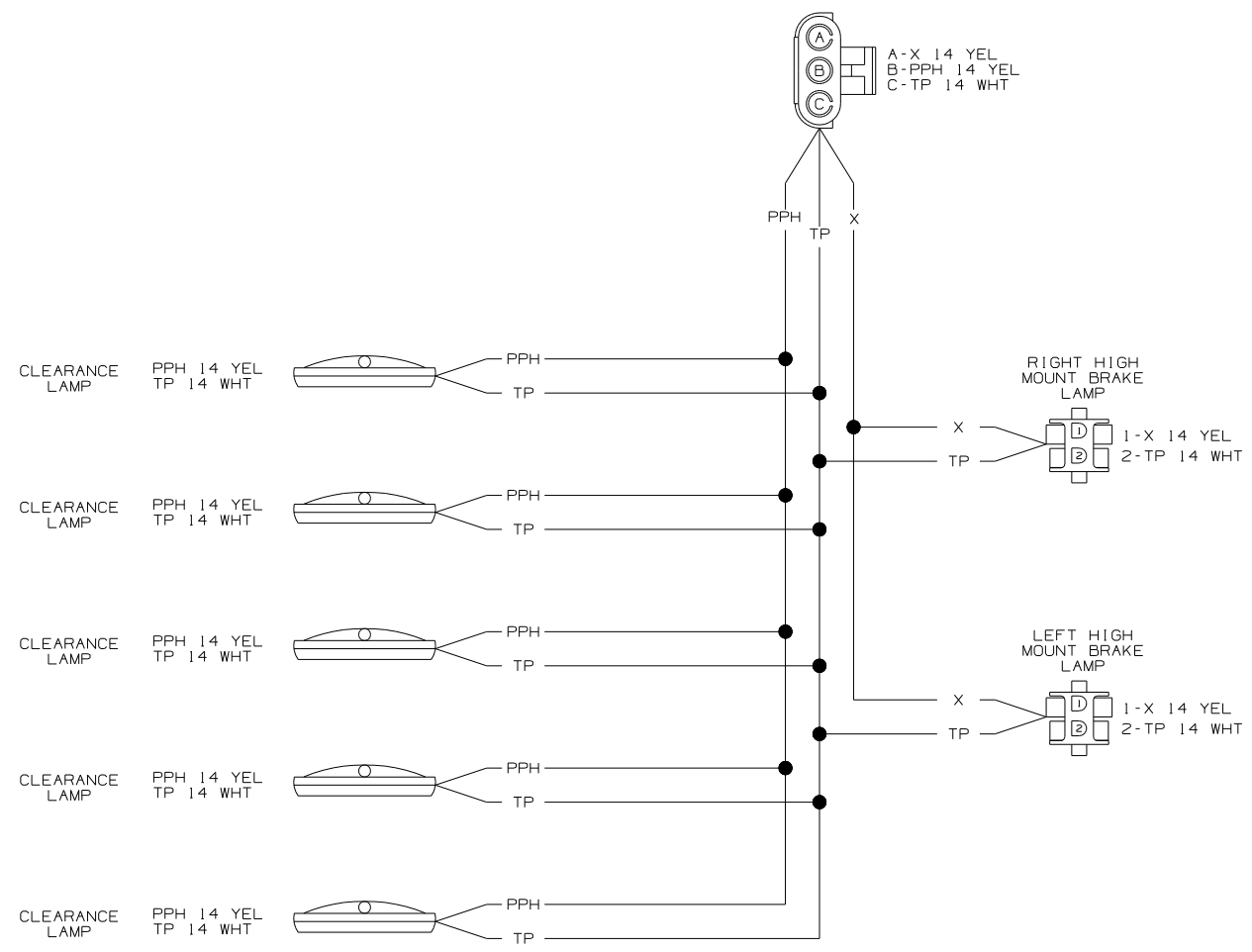

WIRING DIAGRAM-CLEARANCE LAMPS (WIRE ASM 152163 REV-C)

CONNECTS TO WIRE ASM-ROOF

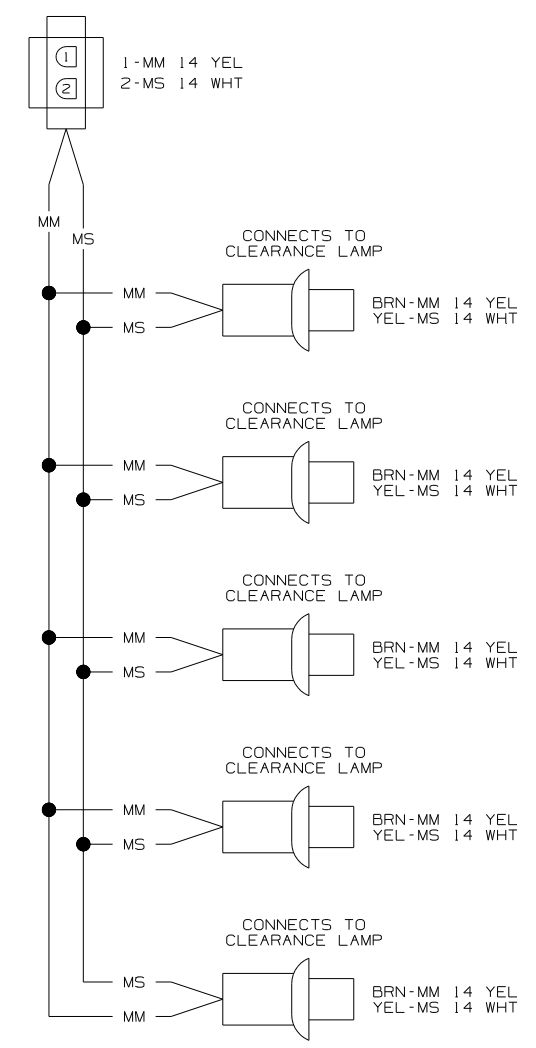

WIRING DIAGRAM-CLEARANCE LAMPS (WIRE ASM 152164 REV-A)

- 5 SEE WIRING DIAGRAM-AUTO FOR ADDITIONAL INFORMATION.
  - 4 SEE MANUFACTURERS DIAGRAM FOR ADDITIONAL INFORMATION.
  - 3 GROUNDS ARE SHOWN AS A SINGLE LINE FOR EASE IN TRACING. EACH GROUND CIRCUIT IS SEPERATE IN THE HARNESS.
  - 2 NOT A SPLICE POINT. INDICATES ENTRY INTO WIRING HARNESS.
1. SPLICES ARE THEORETICAL AND MAY DIFFER IN THE HARNESS.

NOTES:

FIRST USED	07 500-SER
TITLE	DO NOT SCALE DRAWING
TITLE	WIRING DIAGRAM-AUTO LAMPS
SHEET 2	PART NO 156365 REV