

- 10 WRAP PAD AROUND ON THE SIDES OF THE TANK.
 - 9 SEE WIRING INSTL-BODY, 12V FOR ELECTRICAL CONNECTION.
 - 8 SECURE PIPES TO CABINET USING WIRE TIE 108046-02-000, AND SCREW G67-10-12B.
 - 7 SECURE VENT TUBES TO FLOOR WITH CLAMP 62401-02-000 (2), SCREW G67-10-12B (2), BRACKET 136878-01-CHT (2).
 - 6 VENT PIPE MUST PROJECT 51 MIN AND 64 MAX ABOVE ROOF FOR PROPER FIT AND FUNCTION.
5. SEAL AROUND SHOWER WITH SILICONE.
 4. ALL EXTERIOR OPENINGS AROUND PIPE TO BE SEALED WITH 131264-03-000.
 3. ALL PIPE AND FITTINGS TO BE ASSEMBLED WITH SOLVENT 4020-01-000 (USA), 4020-02-000 (CAN)
 2. SLOPE OF TRAP ARM MUST BE 6 PER 305 mm.
 1. SLOPE OF HORIZONTAL PIPING TO BE MIN 3 PER 305 mm.

NOTES:

- 1B1 CODES/STANDARDS USA
- 265 CODES/STDS-CSA/CMVSS
- 43F SHOWER SURROUND
- 23T DRAINAGE SYSTEM-HEATED



| | |
|-----------------------------|-----------------------------------|
| DFTR | ORIG. DATE |
| CHKR | ALL DIMENSIONS ARE IN MILLIMETERS |
| P.E. | |
| M.E. | FIRST USED |
| DSNR | 07 331H |
| UNSPECIFIED TOLERANCES ARE: | MATERIAL: |
| HOLE DIM (X) | : 7 |
| ONE-PLACE (X.X) | : |
| TWO-PLACE (X.XX) | : |
| ANGLE | : |
| THIRD ANGLE PROJECTION | |

FOR DRAINAGE CALLOUTS SEE DWG NO 116229-01-000

| | |
|----------------------|-----------------------|
| DO NOT SCALE DRAWING | |
| TITLE: | DRAINAGE SYSTEM INSTL |
| SHEET 1 OF 3 | PART NO 156533 |

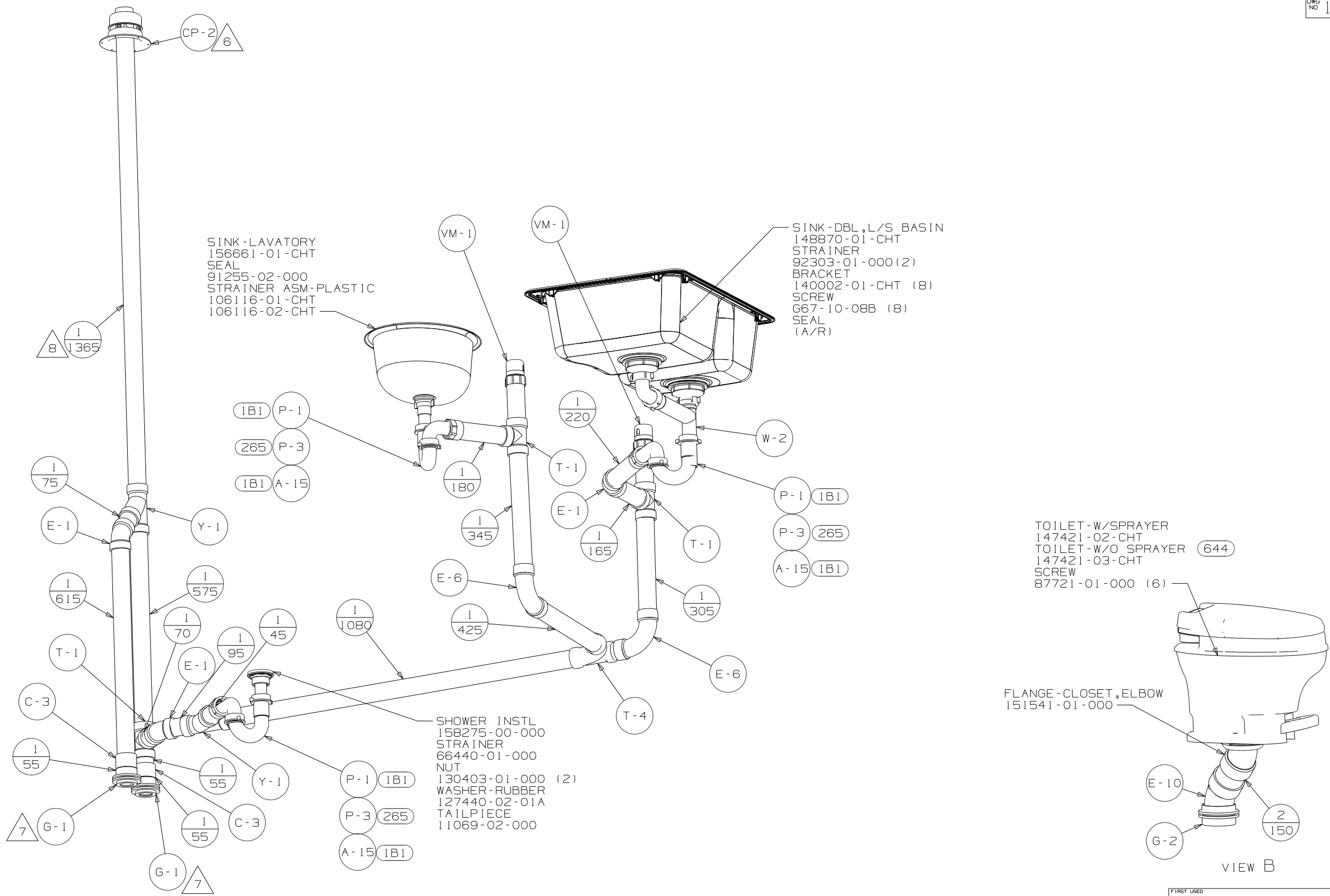

SINK-LAVATORY
 156661-01-CHT
 SEAL
 91255-02-000
 STRAINER ASM-PLASTIC
 106116-01-CHT
 106116-02-CHT

SINK-DBL,L/S BASIN
 148870-01-CHT
 STRAINER
 92303-01-000 (2)
 BRACKET
 140002-01-CHT (8)
 SCREW
 G67-10-08B (8)
 SEAL
 (A/R)

SHOWER INSTL
 158275-00-000
 STRAINER
 66440-01-000
 NUT
 130403-01-000 (2)
 WASHER-RUBBER
 127440-02-01A
 TAILPIECE
 11069-02-000

TOILET-W/SPRAYER
 147421-02-CHT
 TOILET-W/O SPRAYER (644)
 147421-03-CHT
 SCREW
 87721-01-000 (6)

FLANGE-CLOSET, ELBOW
 151541-01-000

VIEW A

VIEW B

| | | | |
|------------|-----------------------|--------|-----|
| FIRST USED | 07 331H | | |
| TITLE | DO NOT SCALE DRAWING | | |
| | DRAINAGE SYSTEM INSTL | | |
| SHEET 2 | PART NO | 156533 | REV |

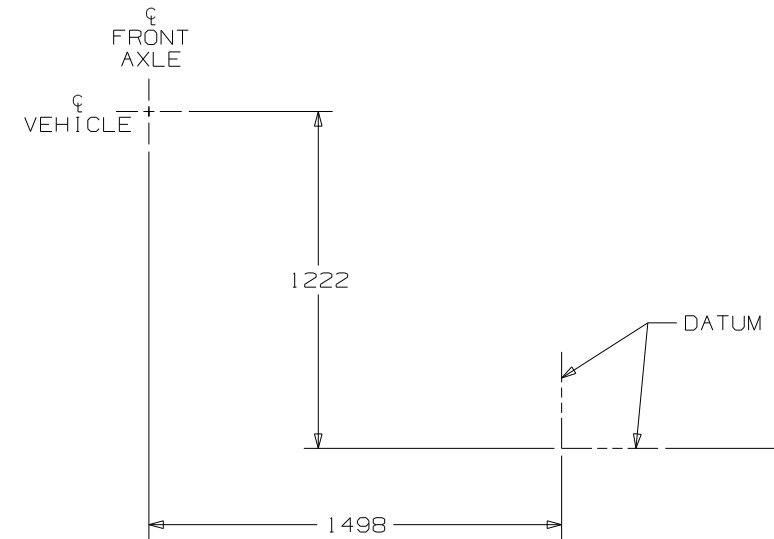

CRADLE ASM
139596-03-CHT
BOLT
C18-05-40A (4)
NUT
D13-05-00B (4)

CRADLE ASM
139597-02-CHT
BOLT
C18-05-40A (4)
NUT
D13-05-00B (4)

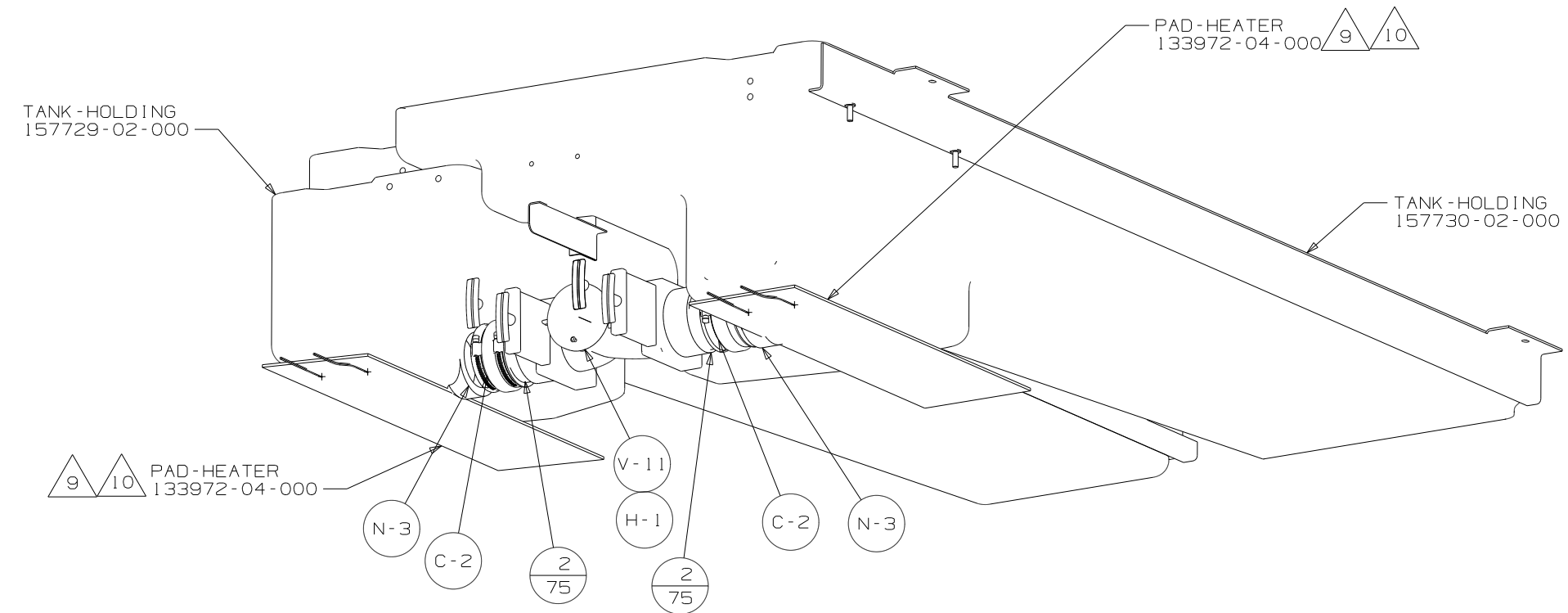
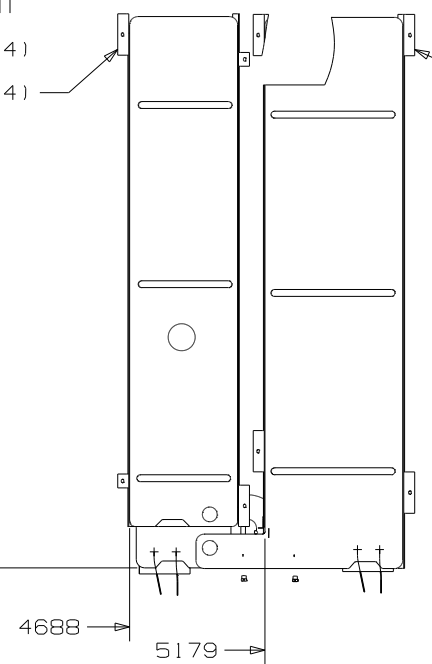

| | | |
|------------|-----------------------|--------|
| FIRST USED | 07 331H | |
| TITLE | DO NOT SCALE DRAWING | |
| | DRAINAGE SYSTEM INSTL | |
| SHEET 3 | PART NO | 156533 |
| | REV | |

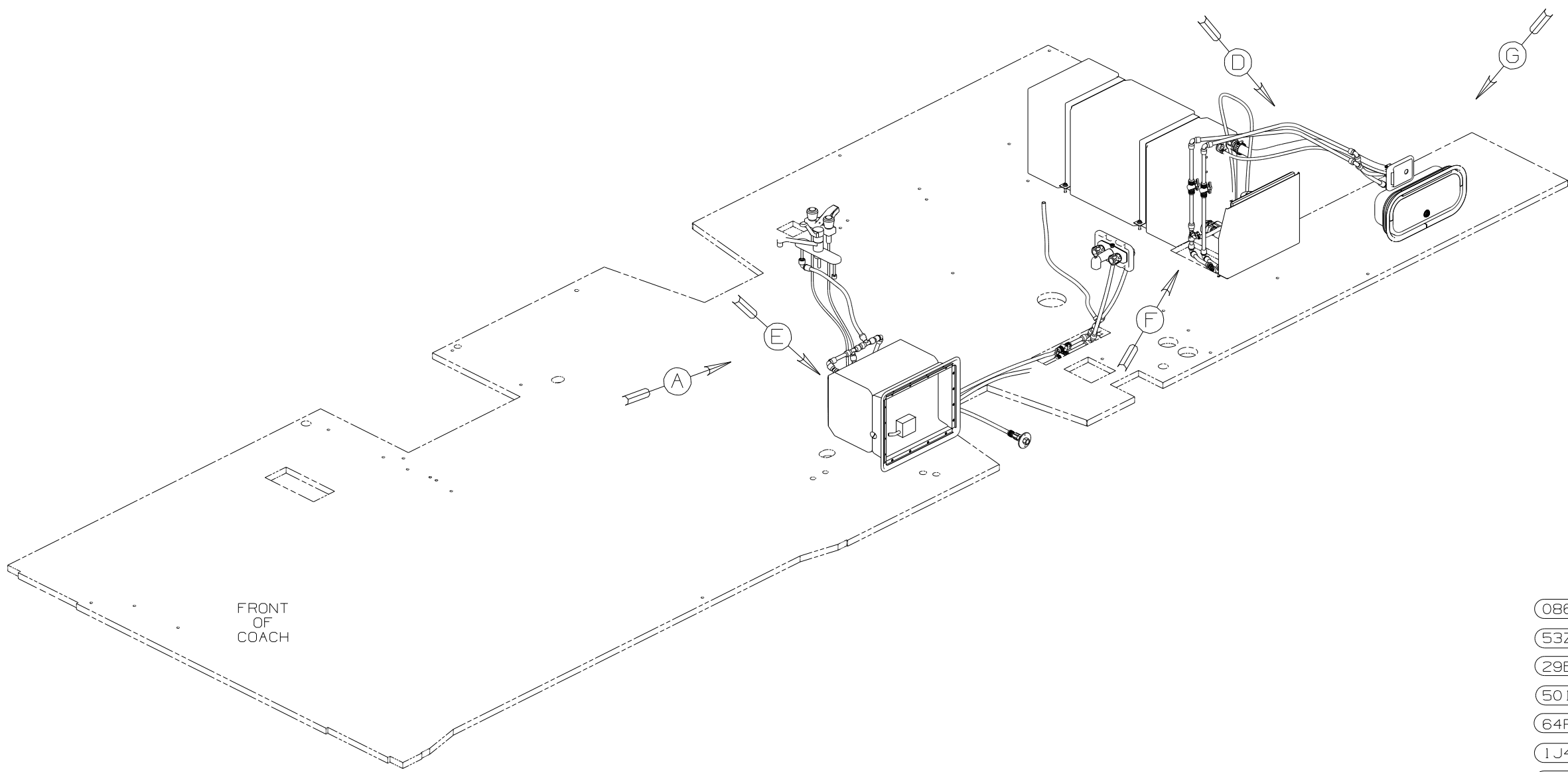

FRONT
OF
COACH

- (086) INTERIOR UPGRADE PACKAGE
- (53Z) WTR HTR-6GAL/110/LP/MTR/AUTO
- (29B) WATER PURIFIER
- (501) WATER PURIFIER-W/O
- (64R) EXTERIOR WASH STATION
- (1J4) EXT WASH STATION-WITHOUT
- (53F) WTR HTR-6 GAL ELEC IGN

- NOTES:
- 7. ADD PIPE WRAP (LADDER SCRAP) INSULATION HERE.
 - 6. ANTI-RATTLE CLAMP 10495-01-000, SCREW G67-10-12B.
 - 5. ADD TEFLON TAPE 10405-01-000 TO FITTING.
 - 4. ADD TEFLON TAPE 10405-02-000 TO FITTING.
3. ALL TUBING TO BE SECURED AT 1200 INTERVALS MAXIMUM WITH CLAMP 10495-01-000 AND SCREW G67-10-12B OR EQUIVALENT.
 2. TUBING TO BE INSTALLED WITH SUFFICIENT SLOPE TO PROVIDE DRAINAGE TO NEAREST VALVE.
 1. PLASTIC FITTINGS TO BE SEALED WITH SEALANT 94456-01-000.

| | | | |
|---------------------------|------------|---|-----|
| WINNEBAGO | | COPYRIGHT 2007 WINNEBAGO INDUSTRIES, INC. | |
| DFTR | ORIG. DATE | ALL DIMENSIONS ARE IN MILLIMETERS | |
| CHKR | | FIRST USED | |
| P.E. | | 07 331H | |
| M.E. | | UNSPECIFIED TOLERANCES ARE: | |
| DSNR | | MATERIAL: | |
| | | WHOLE DIM (X) : | 3 |
| | | ONE-PLACE (X.X) : | |
| | | TWO-PLACE (X.XX) : | |
| | | ANGLE : | |
| THIRD ANGLE PROJECTION | | DO NOT SCALE DRAWING | |
| TITLE: WATER SYSTEM INSTL | | | |
| SHEET 1 OF 4 | PART NO | 157374 | REV |
| REF: | 1 3/9/2007 | | |

(X-X)
FOR
WATER
CALLOUTS
SEE DWG NO
116230-01-000

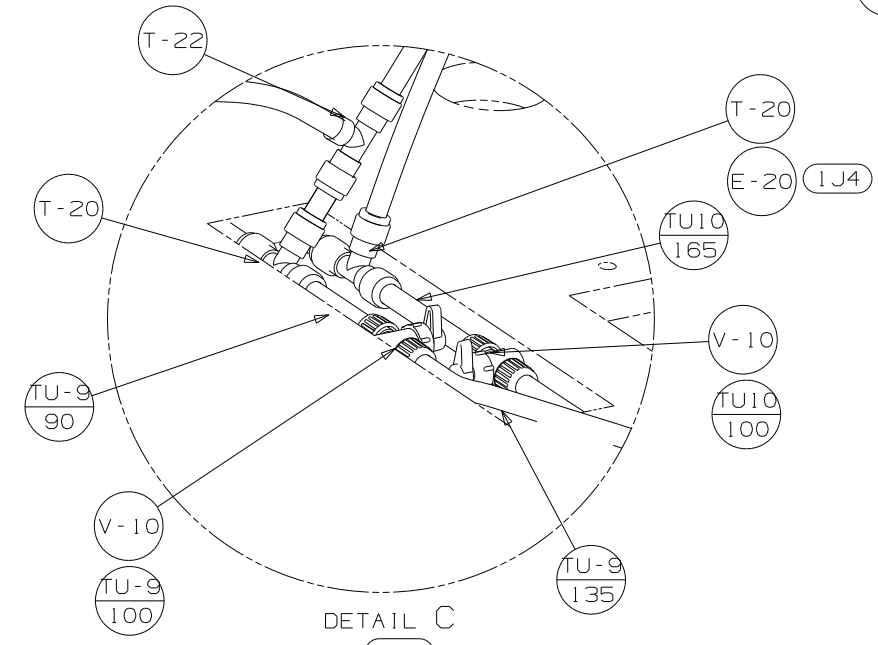
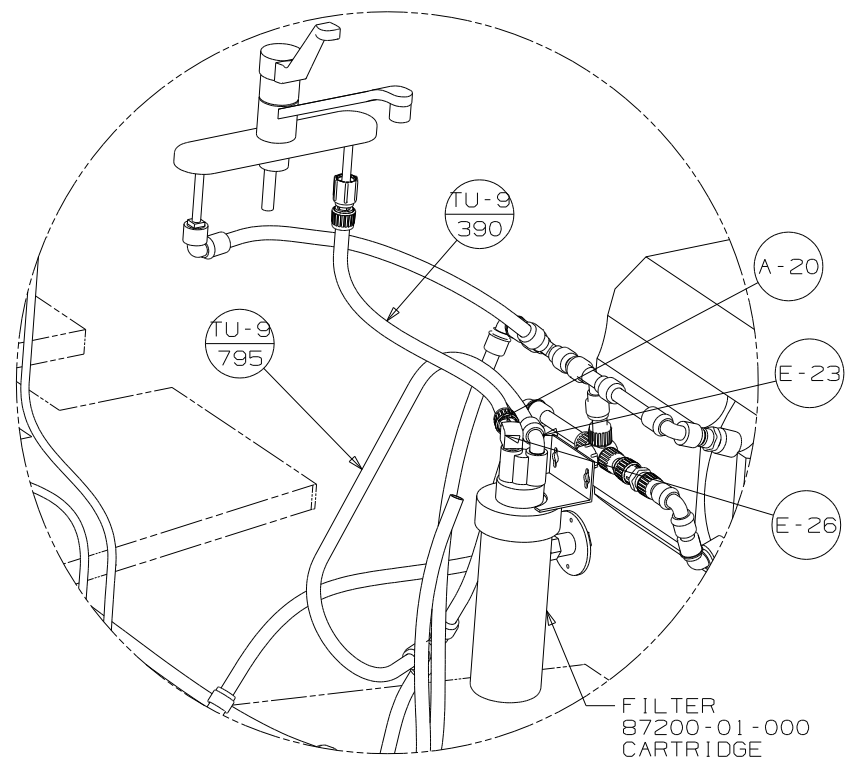
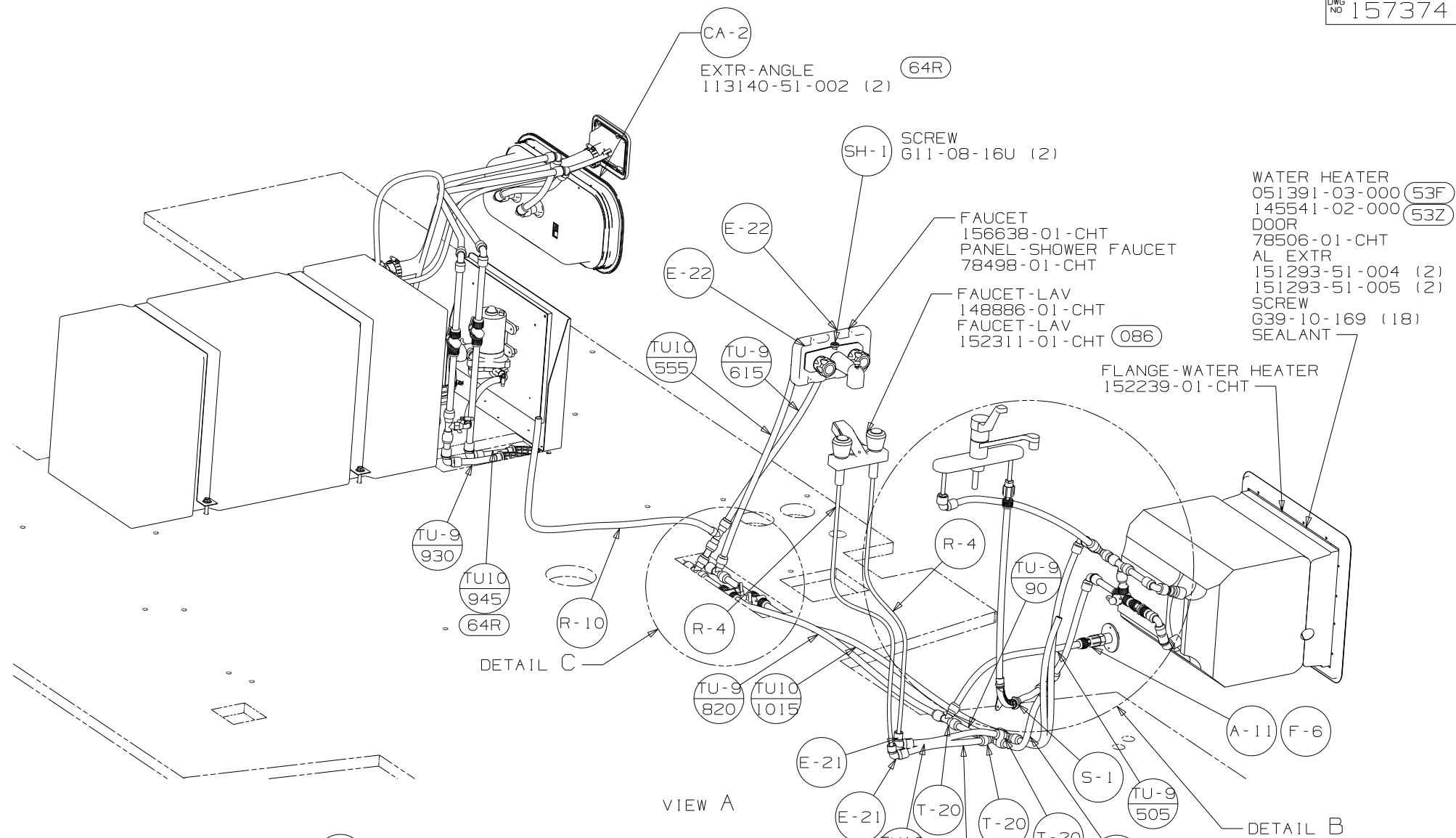

| | |
|----------------------|--------------------|
| FIRST USED | 07 331H |
| DO NOT SCALE DRAWING | |
| TITLE | WATER SYSTEM INSTL |
| SHEET 2 | PART NO 157374 REV |

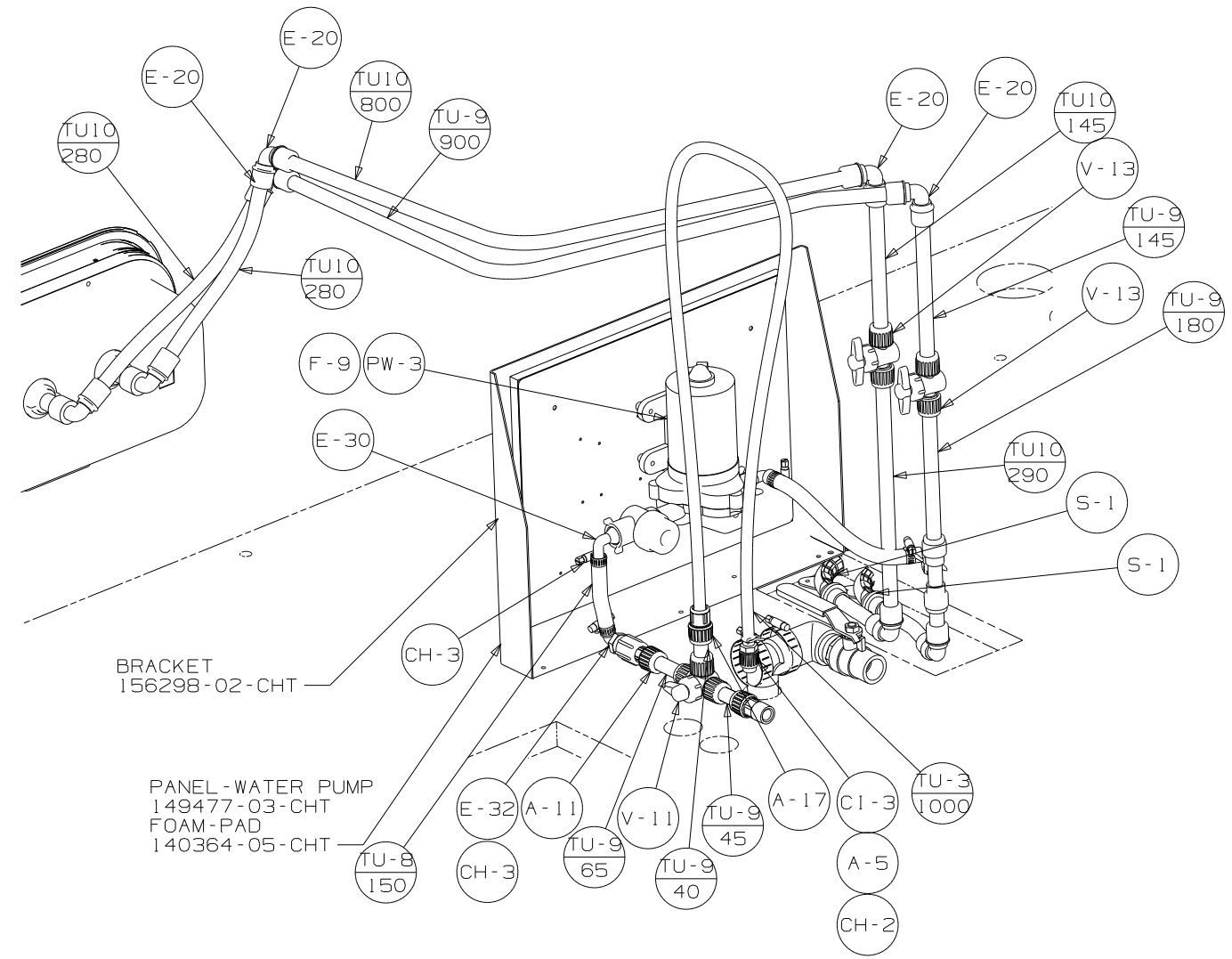

VIEW D

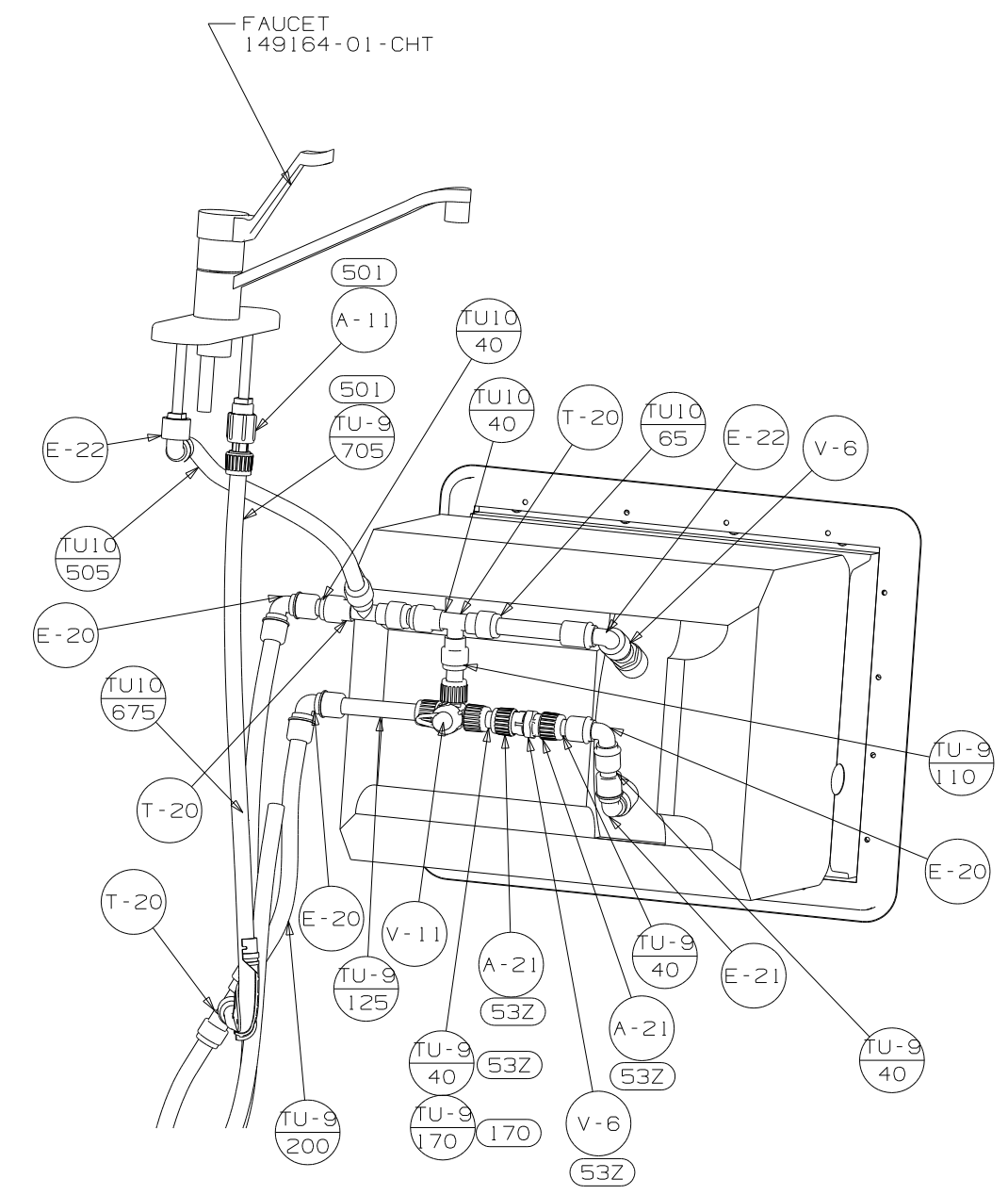

VIEW E

| | | | |
|------------|----------------------|--------|-----|
| FIRST USED | 07 331H | | |
| TITLE | DO NOT SCALE DRAWING | | |
| TITLE | WATER SYSTEM INSTL | | |
| SHEET 3 | PART NO | 157374 | REV |

SCREW
G11-08-12U (4)
SEALANT

TANK ASM-WATER,31 GAL
156167-02-000
STRAP-TANK,WATER
118994-10-CHT (2)
BOLT
C18-05-40A (4)
NUT
D39-05-00B (4)
WASHER
E13-16-00B (4)

ELBOW
132484-01-000
132782-01-000
VALVE
132483-01-000
TUBE
74462-01-000
(100)

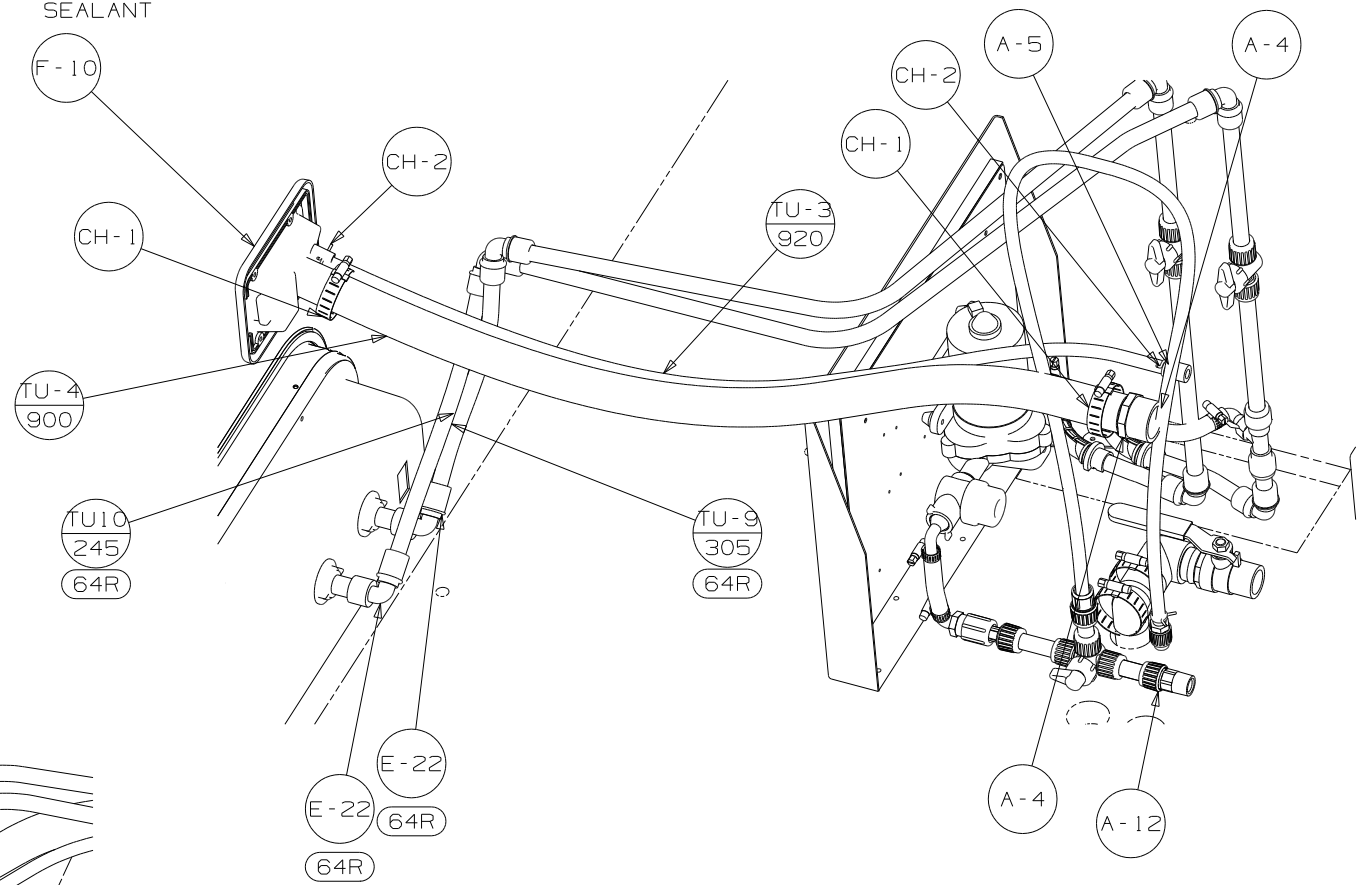
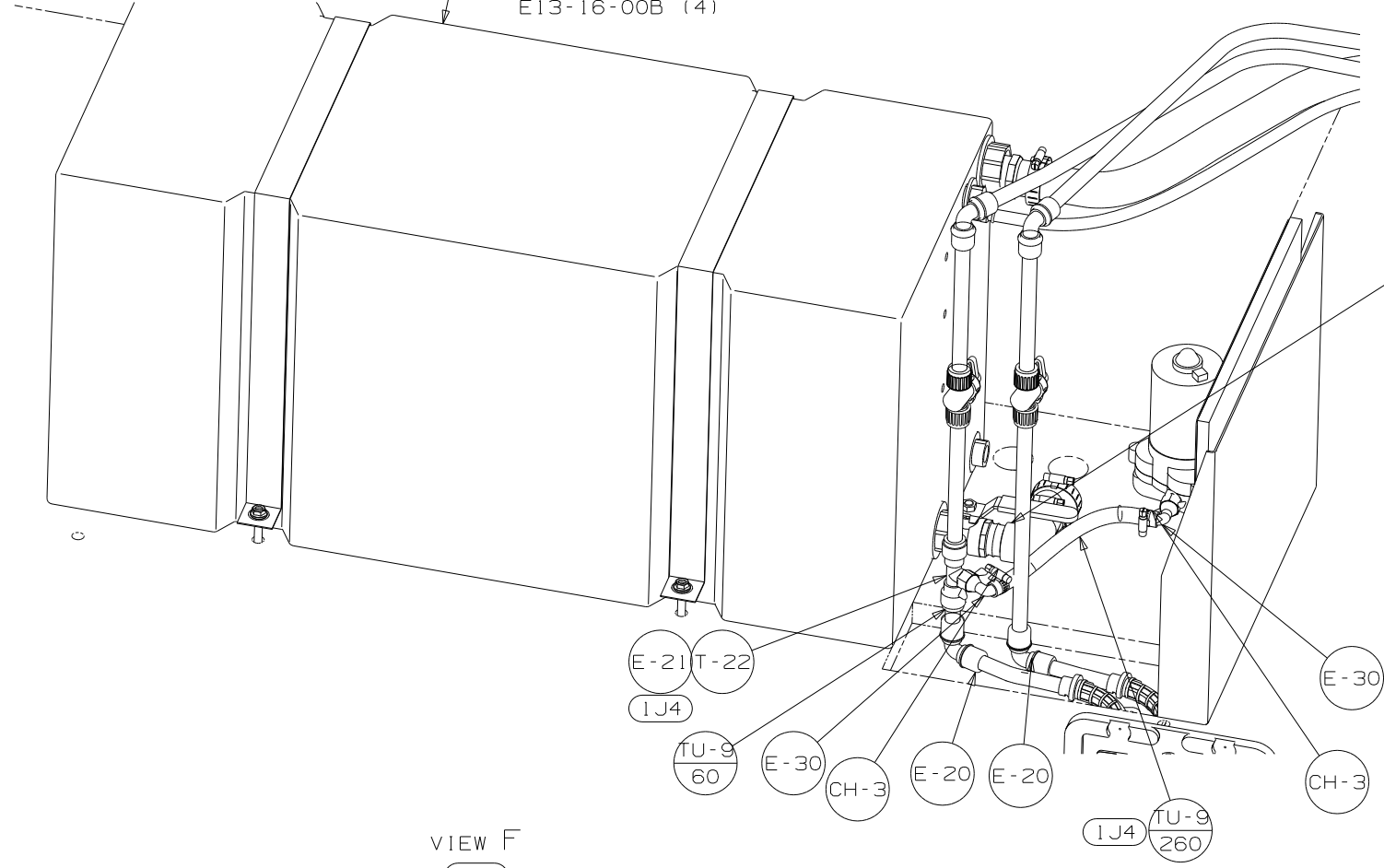

| | |
|----------------------|--------------------|
| FIRST USED | 07 331H |
| DO NOT SCALE DRAWING | |
| TITLE | WATER SYSTEM INSTL |
| SHEET 4 | PART NO 157374 REV |
| 1 3/9/2007 | |