



**DANGER**

**Danger of electrical shock, burns or death.** Always remove all power sources before attempting any repair, service or diagnostic work. Power can be present from shore power, generator, inverter or battery. All power sources must be disabled and secured before performing any service.



**CAUTION**

If you lack the skills, tools or equipment to perform diagnostic or repair work leave such work to an authorized Winnebago Industries dealer or other qualified shop.

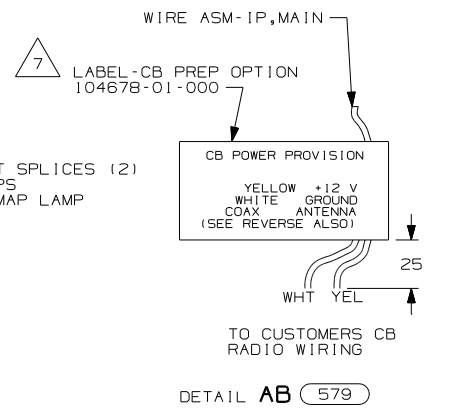
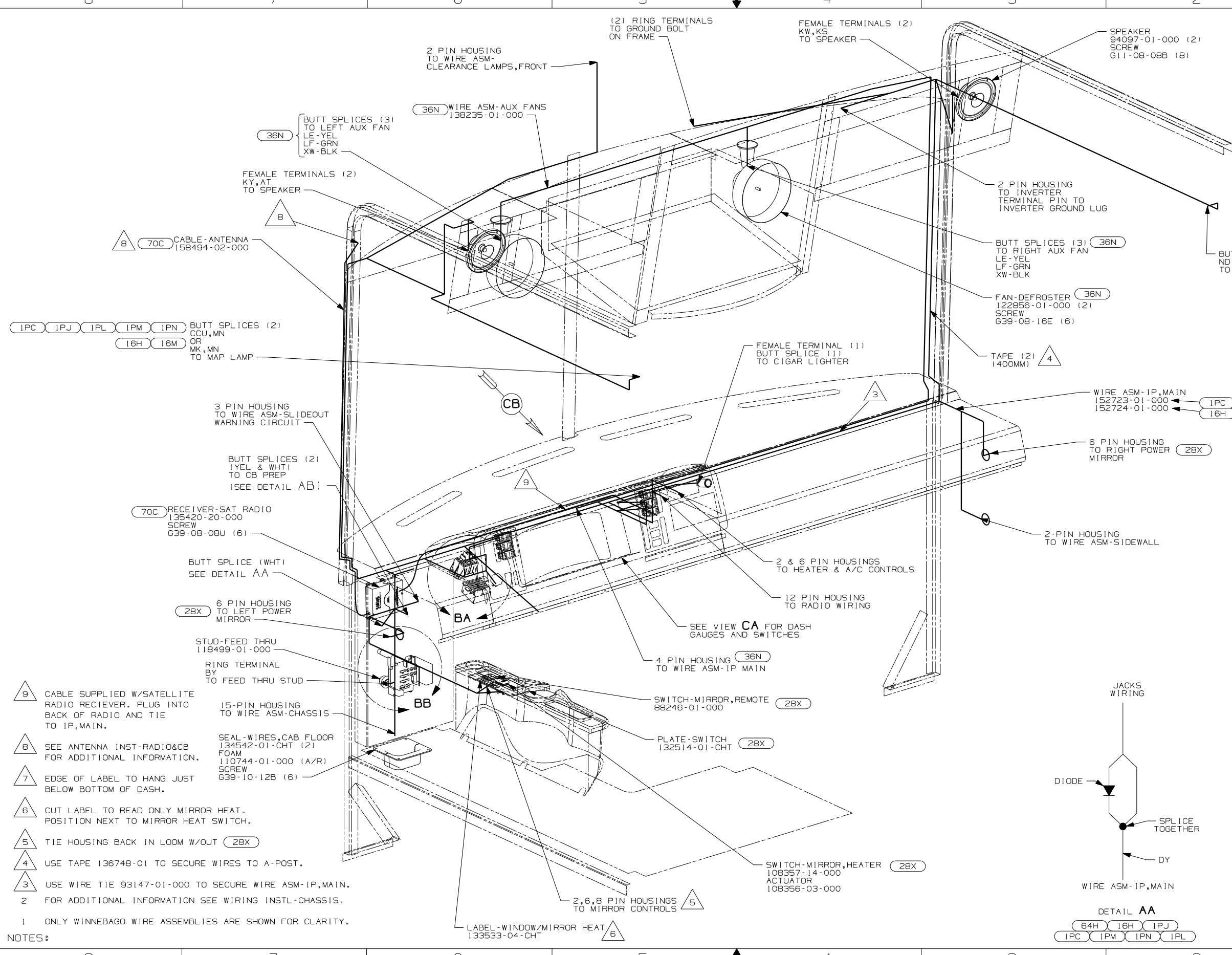

- (IPC) (IPJ) (IPL) (IPM) (IPN) BUTT SPLICES (2) CCU, MN OR MK, MN TO MAP LAMP
- (16H) (16M)
- (70C) CABLE - ANTENNA 158494-02-000
- (36N) WIRE ASM-AUX FANS 138235-01-000
- (36N) BUTT SPLICES (3) TO LEFT AUX FAN LE-YEL LF-GRN XW-BLK
- (36N) BUTT SPLICES (3) TO RIGHT AUX FAN LE-YEL LF-GRN XW-BLK
- (36N) FAN-DEFROSTER 122856-01-000 (2) SCREW 639-08-16E (6)
- (36N) WIRE ASM-IP, MAIN 152723-01-000 152724-01-000
- (IPC) (IPM) (IPN) (IPJ) (IPL) (16H) (16M)
- (28X) 6 PIN HOUSING TO RIGHT POWER MIRROR
- (28X) 2-PIN HOUSING TO WIRE ASM-SIDEWALL
- (28X) 6 PIN HOUSING TO LEFT POWER MIRROR
- (28X) SWITCH-MIRROR, REMOTE 88246-01-000
- (28X) SWITCH-MIRROR, HEATER 108357-14-000 ACTUATOR 108356-03-000
- (28X) 2,6,8 PIN HOUSINGS TO MIRROR CONTROLS
- (28X) 12 PIN HOUSING TO RADIO WIRING
- (28X) 2 & 6 PIN HOUSINGS TO HEATER & A/C CONTROLS
- (36N) 4 PIN HOUSING TO WIRE ASM-IP MAIN
- (36N) BUTT SPLICES (2) (YEL & WHT) TO CB PREP (SEE DETAIL AB)
- (70C) RECEIVER-SAT RADIO 135420-20-000 SCREW 639-08-08U (6)
- (70C) CABLE SUPPLIED W/SATELLITE RADIO RECIEVER. PLUG INTO BACK OF RADIO AND TIE TO IP,MAIN.
- (7) EDGE OF LABEL TO HANG JUST BELOW BOTTOM OF DASH.
- (6) CUT LABEL TO READ ONLY MIRROR HEAT. POSITION NEXT TO MIRROR HEAT SWITCH.
- (5) TIE HOUSING BACK IN LOOM W/OUT (28X)
- (4) USE TAPE 136748-01 TO SECURE WIRES TO A-POST.
- (3) USE WIRE TIE 93147-01-000 TO SECURE WIRE ASM-IP,MAIN.
- (2) FOR ADDITIONAL INFORMATION SEE WIRING INSTL-CHASSIS.
- (1) ONLY WINNEBAGO WIRE ASSEMBLIES ARE SHOWN FOR CLARITY.
- (IPL) WORKHORSE 18,000# GVWR (W18)
- (IPJ) WORKHORSE 16,000# GVWR (W16)
- (70C) RADIO - SATELLITE
- (579) RADIO - CB WIRE PREP
- (IPN) WORKHORSE 20,700#-19.5 TIRE
- (64H) HYDRAULIC LEVELING JACKS
- (16M) FORD CHASSIS 20,500#/V10 ENG
- (28X) MIRRORS-EXTERIOR W/DEFROST
- (16H) FORD CHASSIS 18,000#/V10 ENG
- (IPC) WORKHORSE CHASSIS 15,000LB. GVWR
- (IPM) WORKHORSE CHASSIS-18,000LB.
- (IPM) (IPC) (16H) (16M)

**WINNEBAGO** COPYRIGHT 2004 WINNEBAGO INDUSTRIES, INC.

DTR	ORIG. DATE
CHKR	ALL DIMENSIONS ARE IN MILLIMETERS
P.E.	FIRST USED
M.E.	06 D-SERIES
DSNR	

UNSPECIFIED TOLERANCES ARE: MATERIAL:

WHOLE DIM (X)	:
ONE-PLACE (X.X)	:
TWO-PLACE (X.XX)	:
ANGLE	:

THIRD ANGLE PROJECTION

**DO NOT SCALE DRAWING**

TITLE: WIRING INSTL-FRONT END

SHEET 1 OF 3 PART NO 152095

REF: 1 11/3/2005

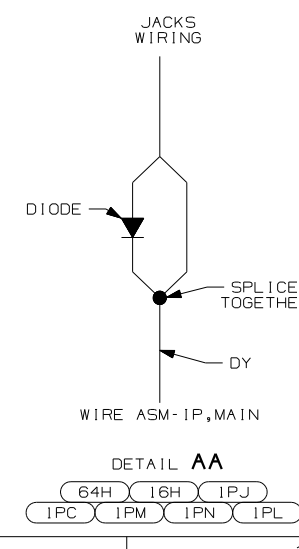

NOTES:

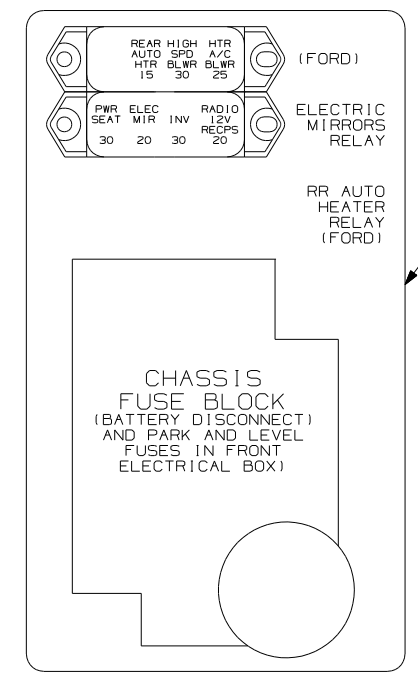
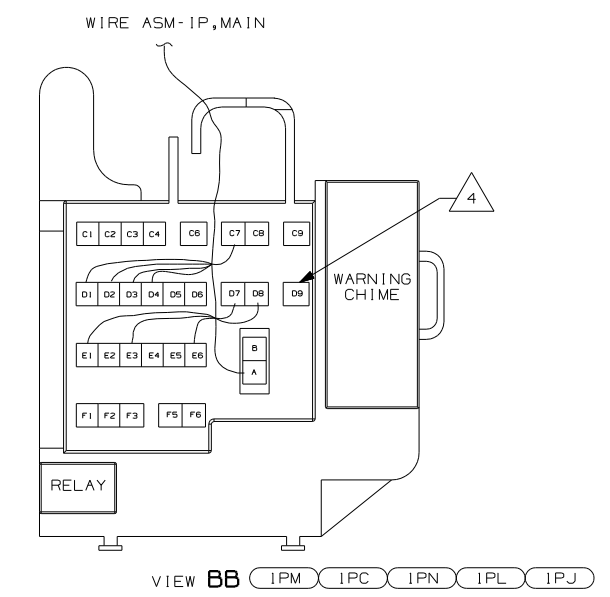
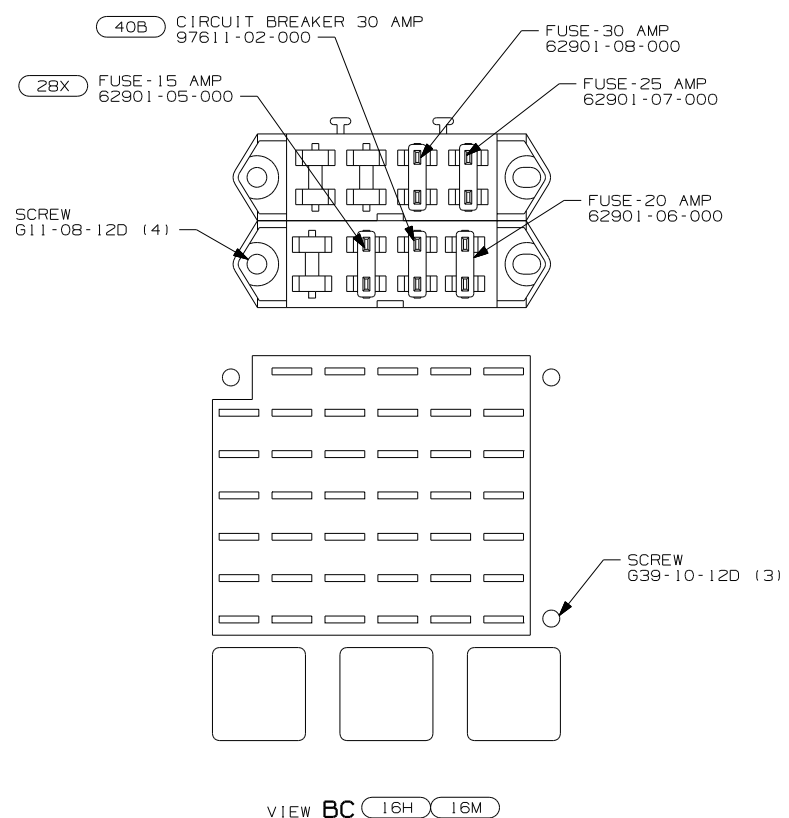
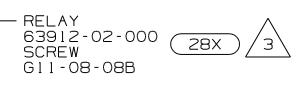
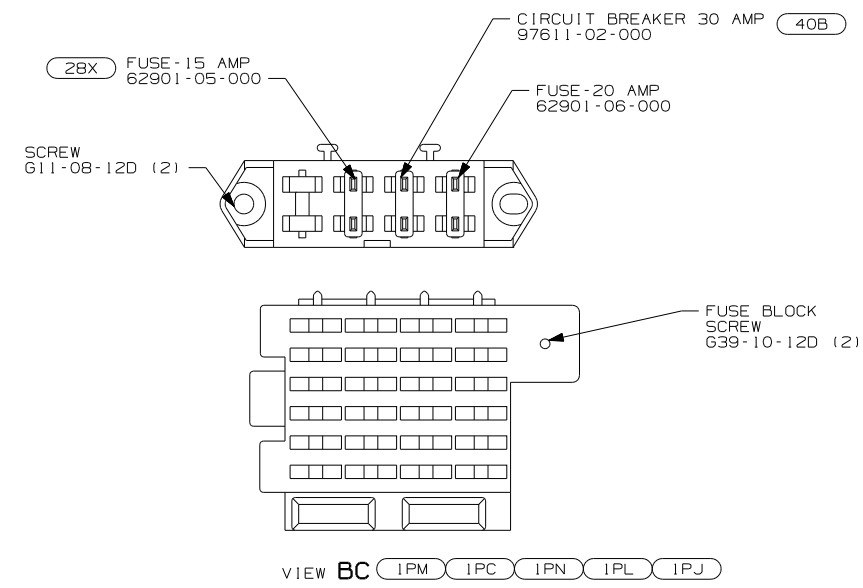
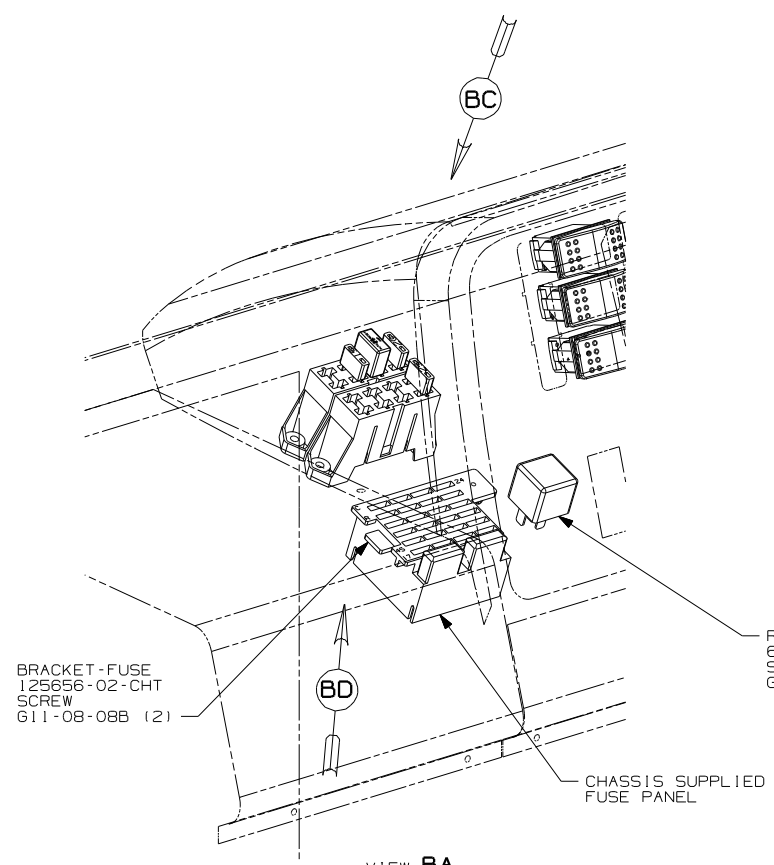

LABEL-FUSES  
111537-08-000

- 1PJ WORKHORSE 16,000# GVWR (W16)
- 1PL WORKHORSE 18,000# GVWR (W18)
- 1PN WORKHORSE 20,700#
- 40B INVERTER-DC/AC, 300 WATT
- 1E2 ENTRANCE STEP-ELEC.
- 28X MIRRORS-EXTERIOR W/DEFROST
- 16M FORD CHASSIS 20,500#/V10 ENG
- 16H FORD CHASSIS 18,000#/V10 ENG
- 1PC WORKHORSE CHASSIS 15,000LB. GVWR
- 1PM WORKHORSE CHASSIS-18,000LB.

FIRST USED	
06 D-SERIES	
DO NOT SCALE DRAWING	
TITLE:	
WIRING INSTL-FRONT END	
SHEET 2	PART NO 152095

- NOTES:
- 4 CONNECT CHASSIS SUPPLIED HOUSING LABELED "SEAT BELT BYPASS" TO POSITION D9 IN CONVENIENCE CENTER.
  - 3 LOCATE WITH MOUNTING HOLE IN STEEL.
  - 2 REPLACE 30A CIRCUIT BREAKER WITH 15 AMP FUSE AND SAVE
  - 1 TRIM FUSE BLOCK SO CIRCUIT BREAKER FITS PROPERLY. REPLACE 25 AMP FUSE AND SAVE FOR USE ELSEWHERE.

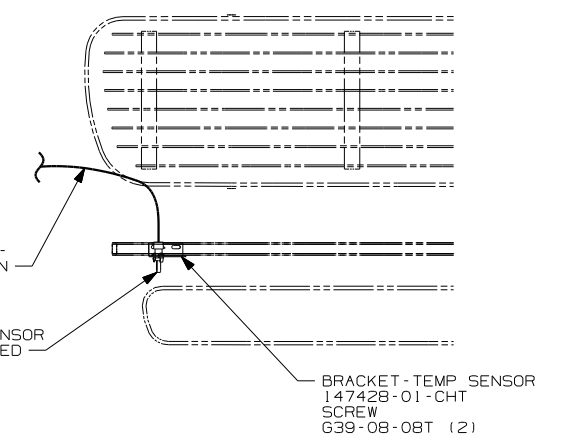
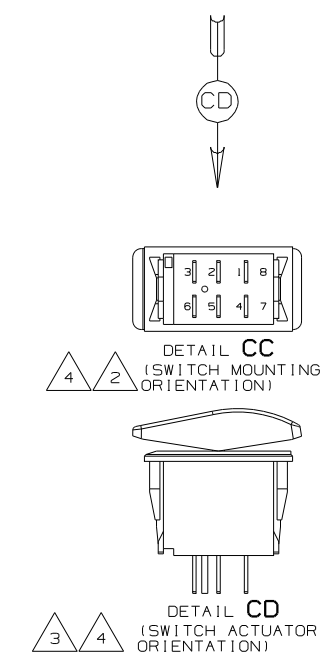
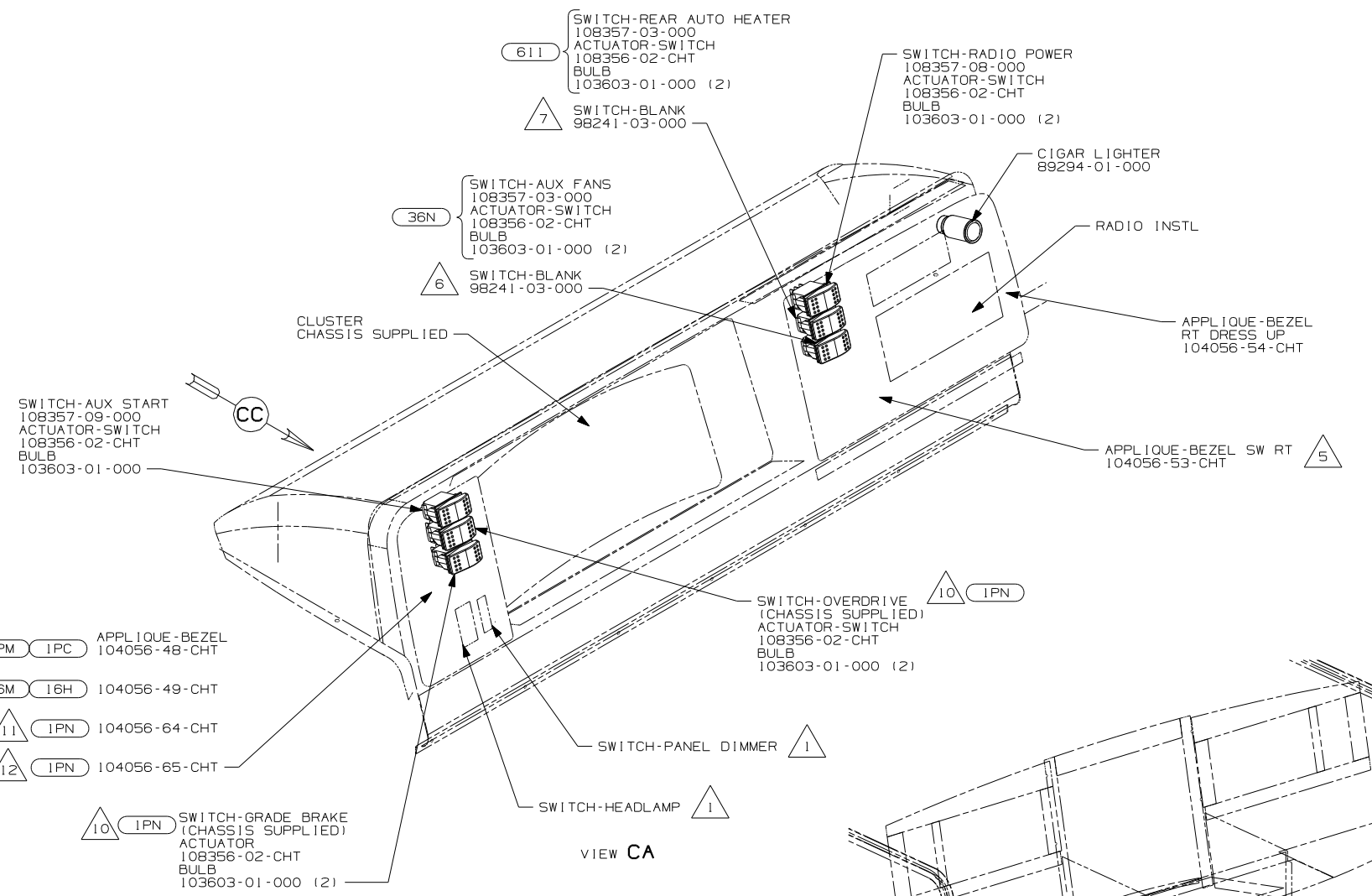

- (1PL) (1PJ) (1PM) (1PC) APPLIQUE-BEZEL 104056-48-CHT
- (16M) (16H) 104056-49-CHT
- (11) (1PN) 104056-64-CHT
- (12) (1PN) 104056-65-CHT
- (10) (1PN) SWITCH-GRABE BRAKE (CHASSIS SUPPLIED) ACTUATOR 108356-02-CHT BULB 103603-01-000 (2)

- (1PC) (1PM) WIRE ASM-WIPER/WASHER 113134-03-000
- (16M) (16H) 111096-03-000
- (1PL) (1PJ) (1PN) 126030-01-000

- (1PC) (1PM) (1PN) (1PL) (1PJ)
- (1PL) WORKHORSE 18,000# GVWR (W18)
- (1PJ) WORKHORSE 16,000# GVWR (W16)
- (265) CODES/STANDARDS-CSA/CMVSS
- (27E) CODES/STANDARDS-CMVSS
- (1PC) (611) WTR HTR-RR AUTO/MOTORAID
- (36N) FANS-DEFROSTER, AUXILIARY
- (16M) FORD CHASSIS 20,500#/V10 ENG
- (16H) FORD CHASSIS 18,000#/V10 ENG
- (1PN) WORKHORSE 20,700#-19.5 TIRE
- (1PM) WORKHORSE CHASSIS-18,000LB.
- (1PC) WORKHORSE CHASSIS 15,000LB. GVWR

- NOTES:
- (12) 2006 WORKHORSE CHASSIS
  - (11) 2005 WORKHORSE CHASSIS
  - (10) CUT CHASSIS SUPPLIED CIRCUIT 8 FROM POSITION 8 IN SWITCH HOUSING AND TAPE BACK INTO LOOM. REMOVE ACTUATOR FROM SUPPLIED SWITCH AND USE NOTED ONE.
  - (9) MOUNT SENSOR BRACKET TO HORIZONTAL TUBE ON FIBERGLASS AS SHOWN.
  - (8) SEND SUPPLIED LOOM TO WIRE PREP FOR MODIFICATIONS AS NOTED IN WIRE ASM-OVERDRIVE SWITCH.
  - (7) WITHOUT (611)
  - (6) WITHOUT (36N)
  - (5) COVER CLEAR LEGEND ON BEZEWL WITH FILM 77031-01-000 (W/BLANK).
  - (4) SWITCH SHOWN WITHOUT WIRE ASM HOUSING CONNECTED.
  - (3) SAME FOR ALL DASH SWITCHES.
  - (2) SAME FOR ALL SWITCHES EXCEPT GENERATOR, AUX START, AND 2005 CHASSIS OVERDRIVE SWITCHES.
  - (1) CHASSIS SUPPLIES

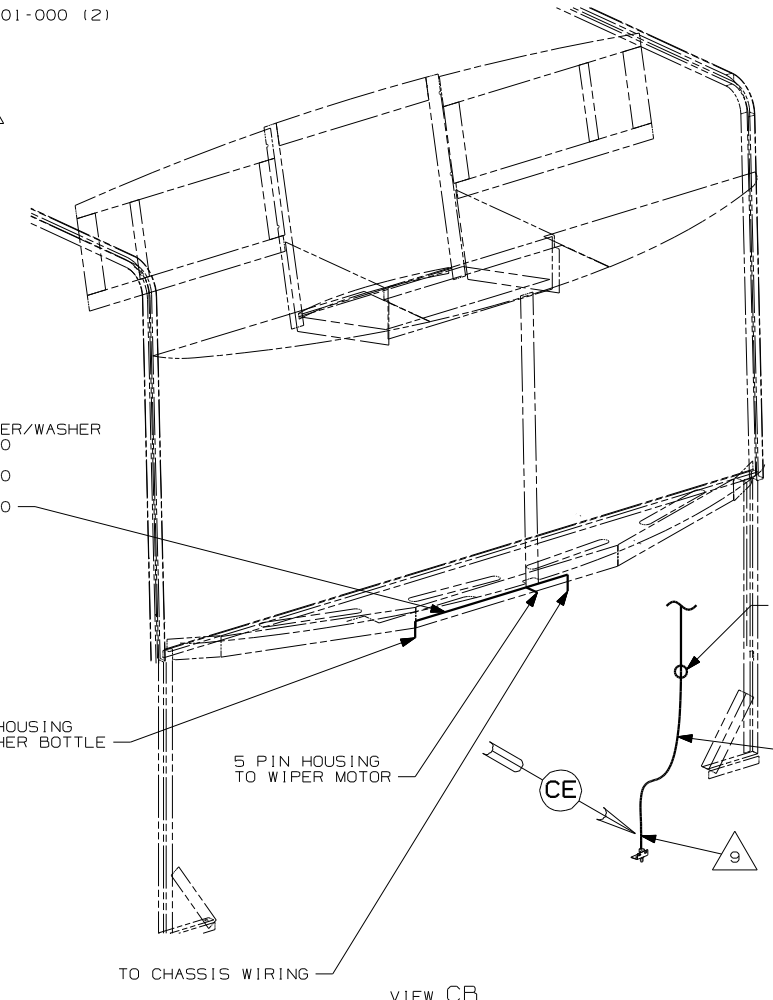

FIRST USED	(1PM) (1PC) (16M) (16H)
06 D-SERIES	
DO NOT SCALE DRAWING	
TITLE: WIRING INSTL-FRONT END	
SHEET 3	PART NO 152095