

- 9 VENT PIPE MUST PROJECT 51 MM MIN AND 64 MM MAX ABOVE ROOF FOR PROPER FIT AND FUNCTION.
- 8 SECURE VENT TUBES TO FLOOR WITH BRACKET 95061-01-000 (2), CLAMP 62401-02-000 AND SCREW G67-10-12B (2).
7. SEAL ALL AROUND SHOWER WITH SILICONE.
 6. SEE DRAWING 61607-01-000 FOR INSTL OF GROMMETS.
 5. SECURE PIPES TO CABINET USING WIRE TIE 108046-02-000 AND SCREW G67-10-12B (8).
 4. ALL EXTERIOR OPENINGS AROUND PIPE TO BE SEALED WITH 110744-01-000.
 3. ALL PIPE AND FITTINGS TO BE ASSEMBLED WITH SOLVENT 4020-01-000 (US), 4020-02-000 (CAN)
 2. SLOPE OF TRAP ARM MUST BE 6 PER 305.
 1. SLOPE OF HORIZONTAL PIPING TO BE 6 PER 305 MIN.

NOTES:

265 CODES/STDS-CSA/CMVSS
 1B1 CODES/STANDARDS-USA

WINNEBAGO		COPYRIGHT 2004 WINNEBAGO INDUSTRIES, INC.	
DFTR	ORIG. DATE	ALL DIMENSIONS ARE IN MILLIMETERS	
CHKR		FIRST USED	
P.E.		06 431C	
M.E.		UNSPECIFIED TOLERANCES ARE:	
DSNR		MATERIAL:	
		WHOLE DIM (X)	: 3
		ONE-PLACE (X.X)	:
		TWO-PLACE (X.XX)	:
		ANGLE	:
THIRD ANGLE PROJECTION		DO NOT SCALE DRAWING	
TITLE: DRAINAGE SYSTEM INSTL			
SHEET 1 OF 3		PART NO 154255	

(X-X)
 FOR
 DRAINAGE
 CALLOUTS
 SEE DWG NO
 116229-01-000

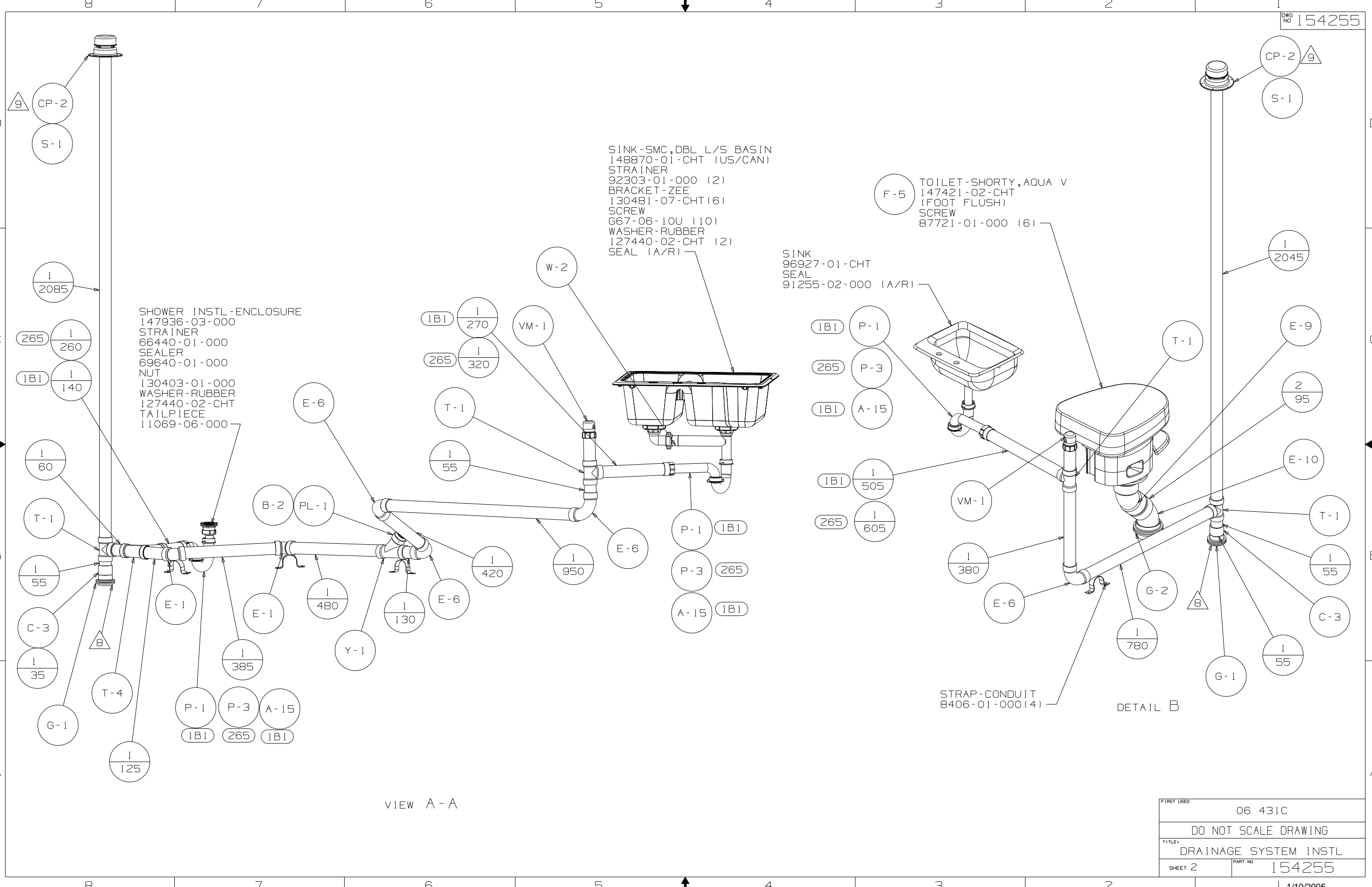

SHOWER INSTL-ENCLOSURE
 147936-03-000
 STRAINER
 66440-01-000
 SEALER
 69640-01-000
 NUT
 130403-01-000
 WASHER-RUBBER
 127440-02-CHT
 TAILPIECE
 11069-06-000

SINK-SMC, DBL L/S BASIN
 148870-01-CHT (US/CAN)
 STRAINER
 92303-01-000 (2)
 BRACKET-ZEE
 130481-07-CHT (6)
 SCREW
 G67-06-10U (10)
 WASHER-RUBBER
 127440-02-CHT (2)
 SEAL (A/R)

F-5 TOILET-SHORTY, AQUA V
 147421-02-CHT
 (FOOT FLUSH)
 SCREW
 87721-01-000 (6)

SINK
 96927-01-CHT
 SEAL
 91255-02-000 (A/R)

STRAP-CONDUIT
 8406-01-000 (4)

VIEW A-A

DETAIL B

FIRST USED	06 431C
DO NOT SCALE DRAWING	
TITLE	DRAINAGE SYSTEM INSTL
SHEET 2	PART NO 154255

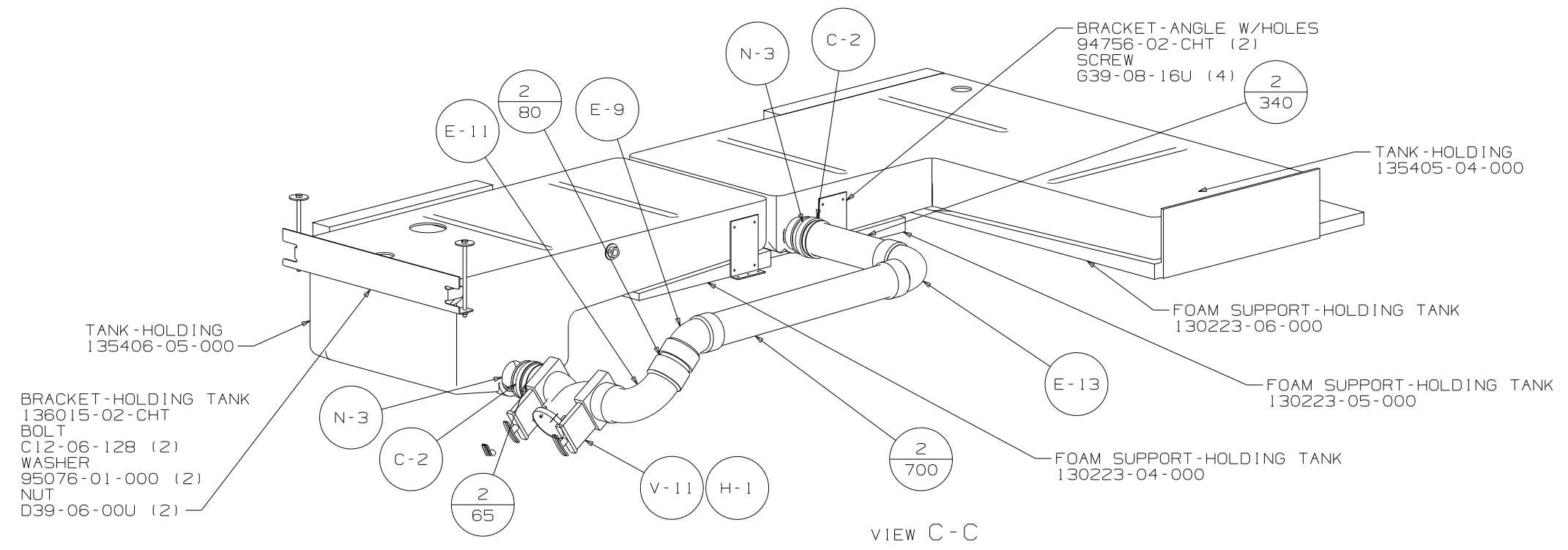
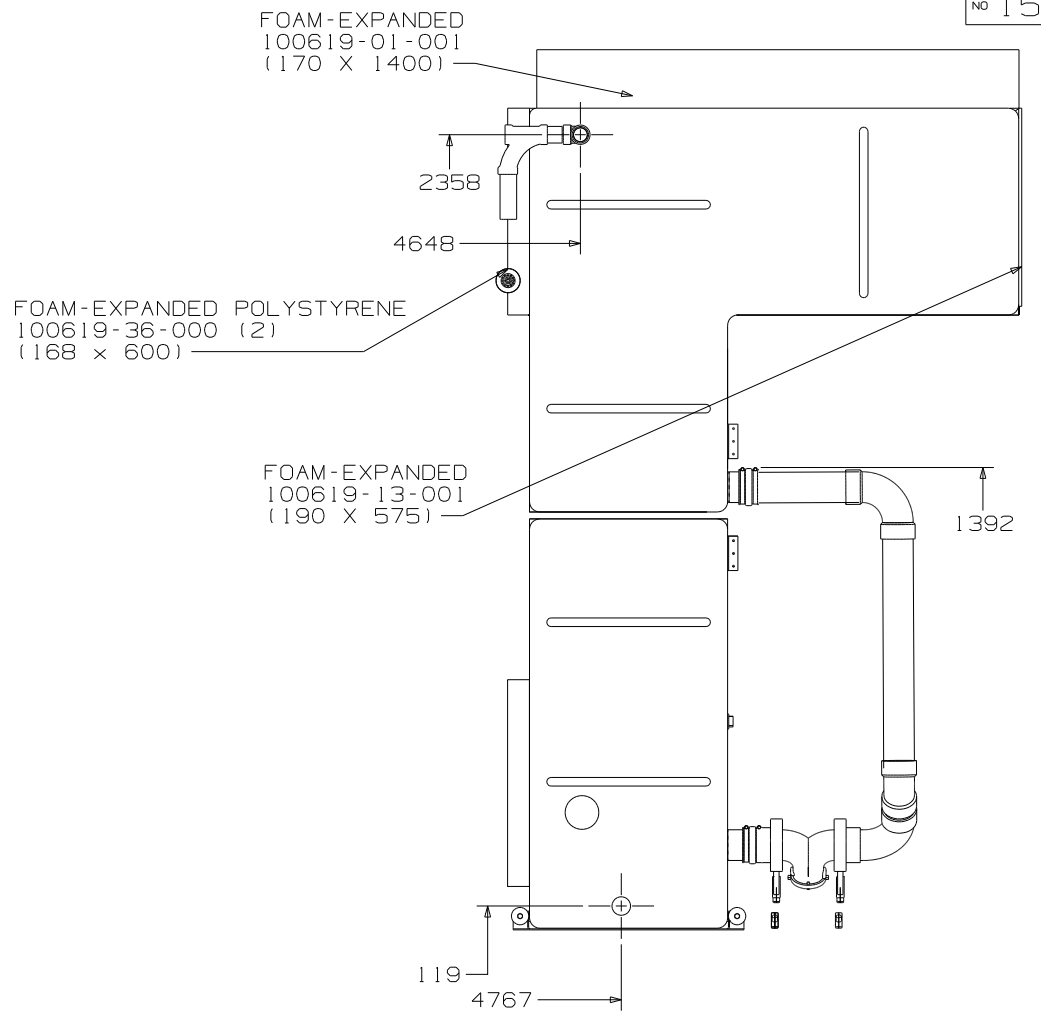
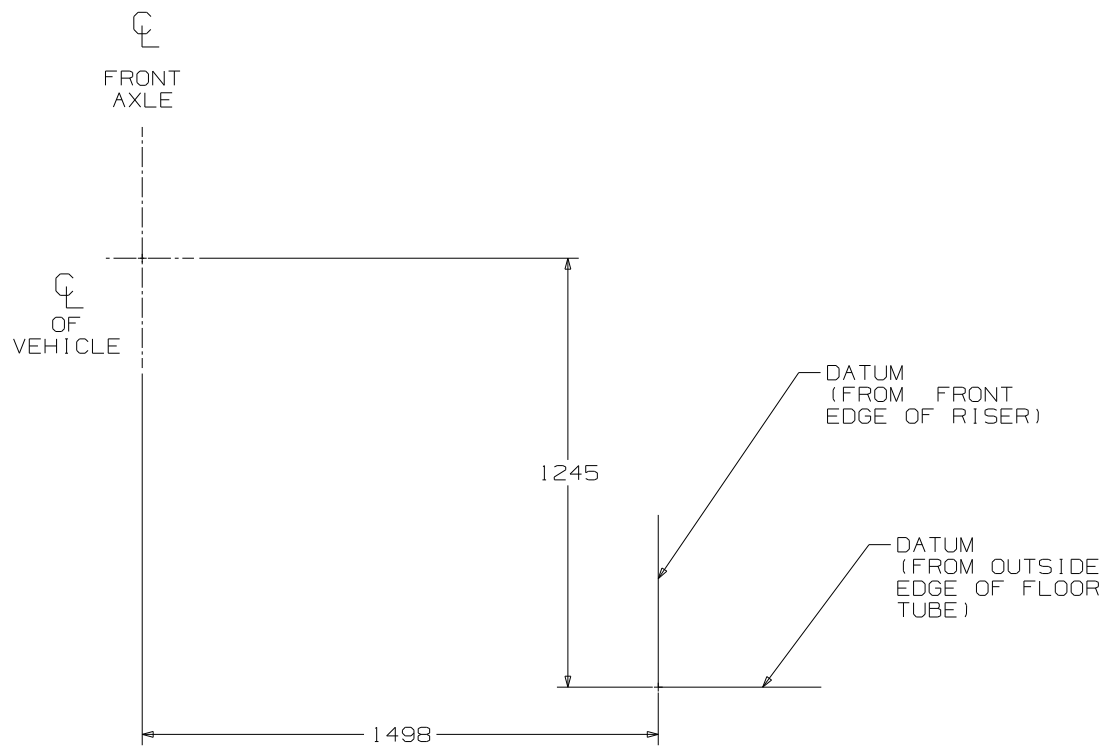

FIRST USED	06 431C
DO NOT SCALE DRAWING	
TITLE	DRAINAGE SYSTEM INSTL
SHEET 3	PART NO 154255

8 7 6 5 4 3 2 1

RELEASE	REV DATE	DWG NO
A		154253
REV ZONE	REVISION RECORD	DATE DFR-016

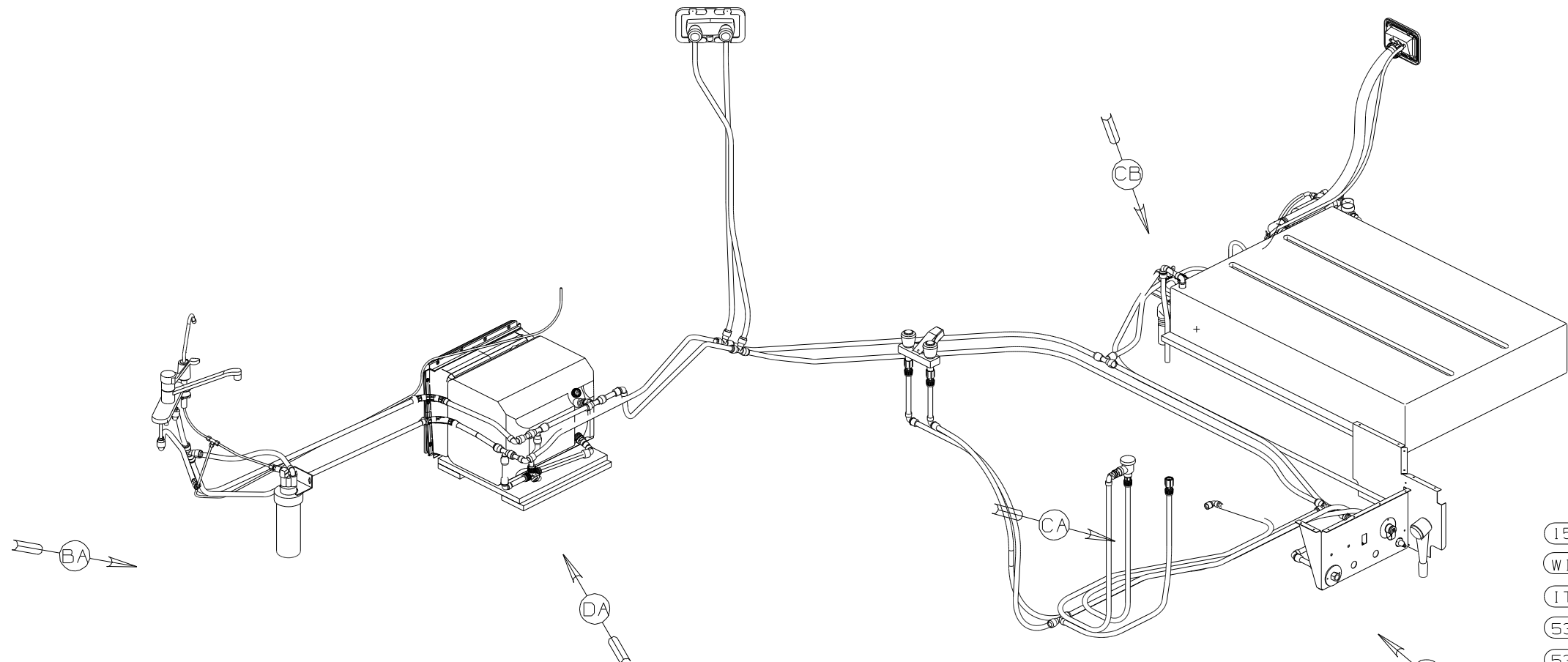

FRONT
OF
COACH

- (15U) REFRIGERATOR/FRZR W/ICEMAKER
- (WIN) WINNEBAGO ONLY
- (1TA) ITASCA ONLY
- (53F) WATER HEATER-ELEC IGN
- (53D) WATER HTR-6GAL/ELEC/LP/MOTORAID
- (501) WATER PURIFIER-W/O
- (29B) WATER PURIFIER
- (64R) EXTERIOR WASH STATION
- (53E) WATER SYSTEM WINTERIZATION PKG

- NOTES:
- 5 ADD TEFLON TAPE 10405-02-000 TO FITTING.
 - 4 ADD TEFLON TAPE 10405-03-000 TO FITTING.
 - 3. ALL TUBING TO BE SECURED AT 1200 INTERVALS MAX WITH CLAMP 10495-01-000 OR CLIP 91951-01-000 AND SCREW G67-10-12B.
 - 2. TUBING TO BE INSTALLED WITH SUFFICIENT SLOPE TO PROVIDE DRAINAGE TO NEAREST VALVE.
 - 1. PLASTIC FITTINGS TO BE SEALED WITH SEALANT 84456-01-000.

X-X
FOR
WATER
CALLOUTS
SEE DWG NO.
116230-01-000

WINNEBAGO		COPYRIGHT 2005 WINNEBAGO INDUSTRIES, INC.	
DFTR	ORIG. DATE	ALL DIMENSIONS ARE IN MILLIMETERS	
CHKR		FIRST USED	
P.E.		06 431C	
M.E.		UNSPECIFIED TOLERANCES ARE:	
DSNR		MATERIAL:	
		WHOLE DIM (X) :	7
		ONE-PLACE (X.X) :	
		TWO-PLACE (X.XX) :	
		ANGLE :	
THIRD ANGLE PROJECTION		DO NOT SCALE DRAWING	
TITLE: WATER SYSTEM INSTL			
SHEET 1 OF 4		PART NO 154253	
REF:		1 10/26/2005	

8 7 6 5 4 3 2 1

SHOWER HEAD-W/HOSE & BRKT
129390-04-CHT

SHOWER BACKWALL

SHOWER SIDEWALL

FAUCET
79563-03-CHT
PANEL
78498-01-CHT
SCREW
611-08-12U (6)
COVER
78500-01-CHT (6)

FAUCET
148886-01-CHT
GASKET
91253-01-000

FAUCET (29B)
103635-01-000

FAUCET
149164-01-CHT
SPACER
137079-02-CHT

BREAKER-VACUUM
125697-04-000
CHECK VALVE
125697-03-000

FILTER (29B)
87200-01-000
CARTRIDGE
87200-02-000
SCREW
667-10-12U (2)

VIEW BA

VIEW BB

FIRST USED	06 431C
TITLE	DO NOT SCALE DRAWING
TITLE	WATER SYSTEM INSTL
SHEET 2	PART NO 154253

- WATER HEATER 53F
51391-03-000
- 145541-02-000 53D
- FLANGE-WATER HEATER 6 GAL
152239-01-CHT
- DOOR
78506-01-CHT
- 78506-01-CHT
- AL EXTR
2726-01-210 (2)
- 2726-01-212 (2)
- SCREW
G39-10-169 (18)
- SEALANT

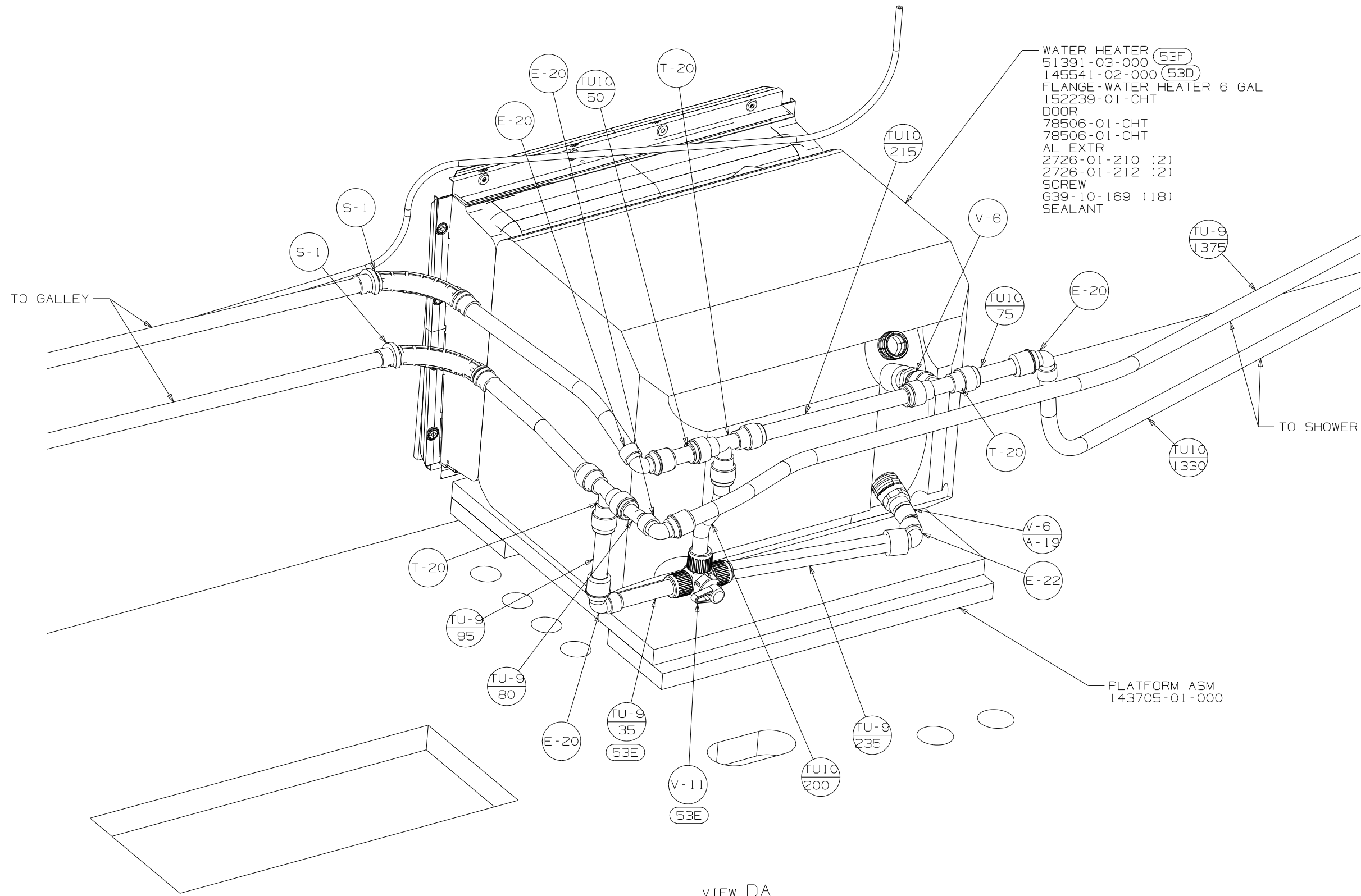

VIEW DA

FIRST USED	06 431C
DO NOT SCALE DRAWING	
TITLE	WATER SYSTEM INSTL
SHEET 4	PART NO 154253