

9. VENT PIPE MUST PROJECT 51 MM MIN AND 64 MM MAX ABOVE ROOF FOR PROPER FIT AND FUNCTION.
8. SEE DRAWING 61607-01-000 FOR INSTL OF GROMMETS.
7. SEAL ALL AROUND SHOWER WITH SILICONE.
6. SECURE VENT TUBES TO FLOOR WITH CLAMP 62401-02-000 (3); SCREW G67-10-12B (3); AND BRACKET 136878-01-CHT (3).
5. SECURE PIPES TO CABINET USING WIRE TIE 108046-02-000 AND SCREW G67-10-12B (8).
4. ALL EXTERIOR OPENINGS AROUND PIPE TO BE SEALED WITH 110744-01-000.
3. ALL PIPE AND FITTINGS TO BE ASSEMBLED WITH SOLVENT 4020-01-000.
2. SLOPE OF TRAP ARM MUST BE 6 PER 305.
1. SLOPE OF HORIZONTAL PIPING TO BE 6 PER 305 MIN.

NOTES:

- (1B1) CODES/STANDARDS-USA
- (265) CODES/STDS-CSA/CMVSS
- (23T) HEATED HOLDING TANKS

WINNEBAGO		COPYRIGHT 2006 WINNEBAGO INDUSTRIES, INC.	
DFTR	ORIG. DATE	ALL DIMENSIONS ARE IN MILLIMETERS	
CHKR		FIRST USED	
P.E.		06 325F	
M.E.		UNSPECIFIED TOLERANCES ARE:	
DSNR		MATERIAL:	
		WHOLE DIM (X) :	3
		ONE-PLACE (X.X) :	
		TWO-PLACE (X.XX) :	
		ANGLE :	
		THIRD ANGLE PROJECTION	
DO NOT SCALE DRAWING			
TITLE: DRAINAGE SYSTEM INSTL			
SHEET 1 OF 3	PART NO	153559	REV
REF:	1 6/13/2006		

(X-X)
FOR
DRAINAGE
CALLOUTS
SEE DWG NO.
116229-01-000

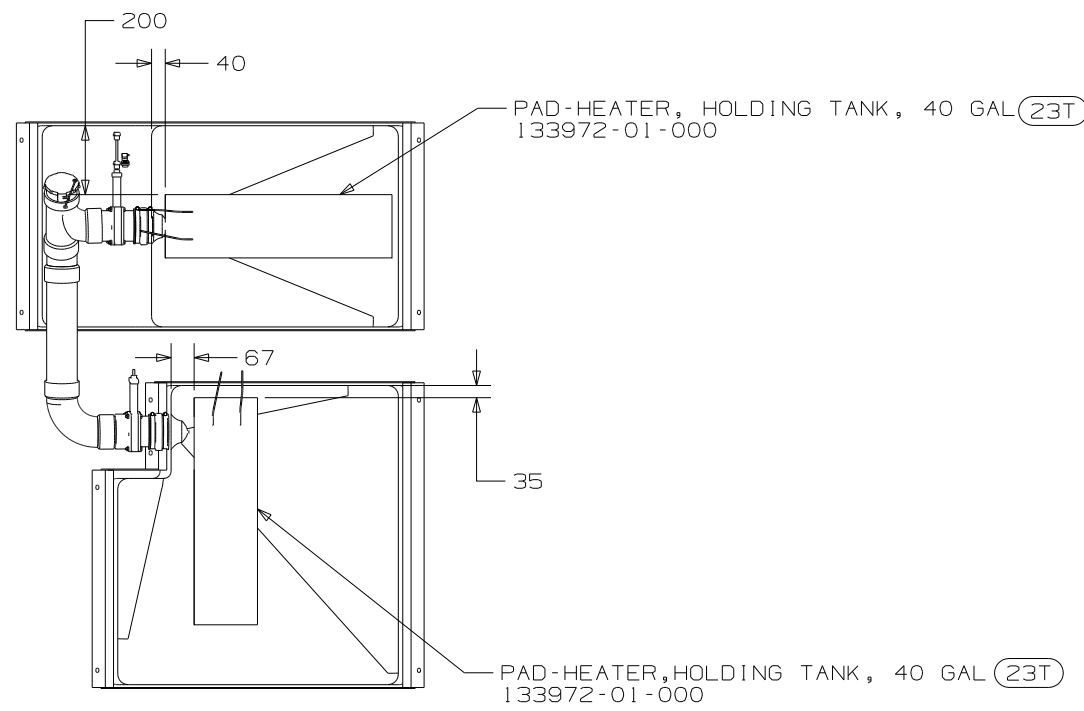
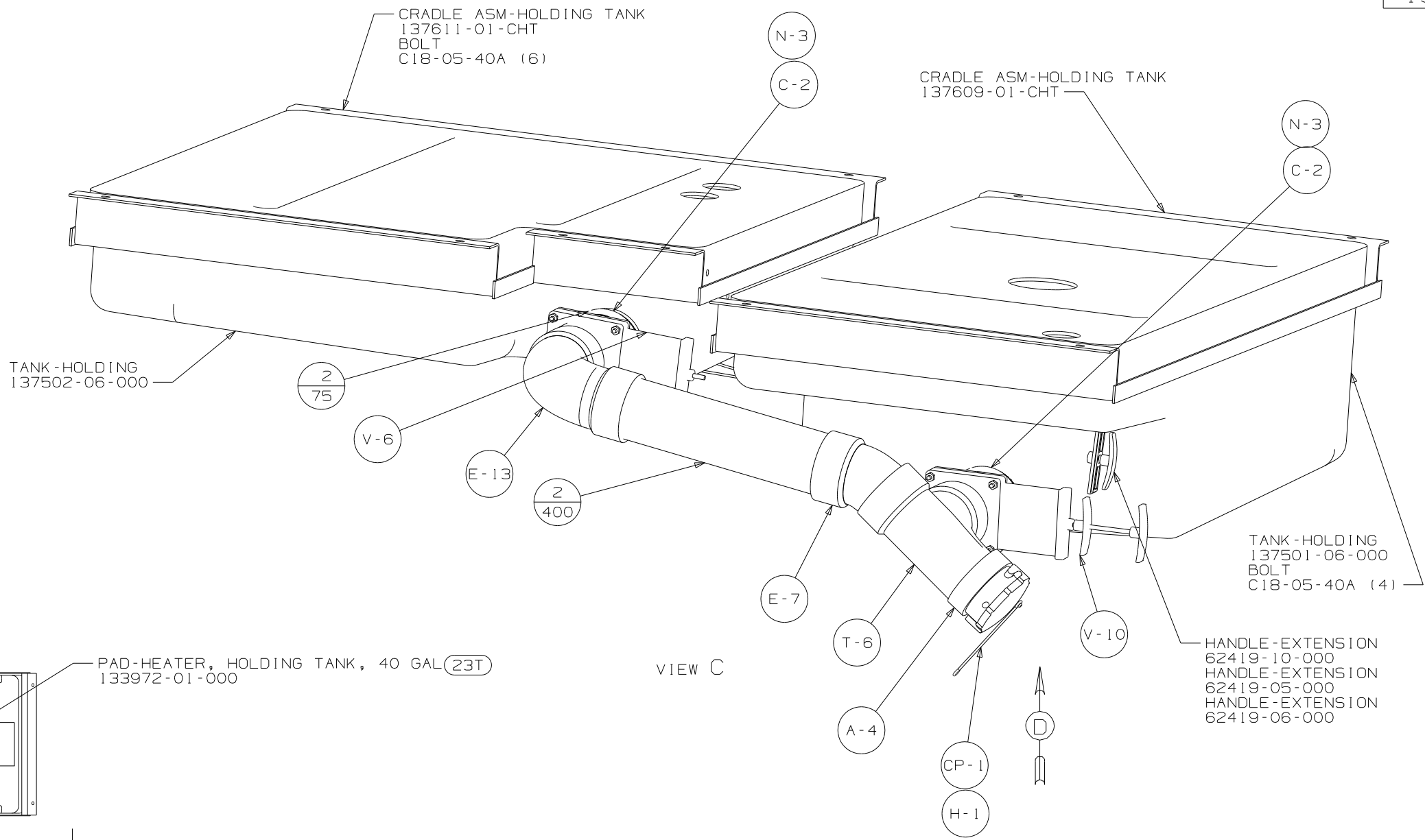

FIRST USED	06 325F	
TITLE	DO NOT SCALE DRAWING	
	DRAINAGE SYSTEM INSTL	
SHEET 3	PART NO 153559	REV

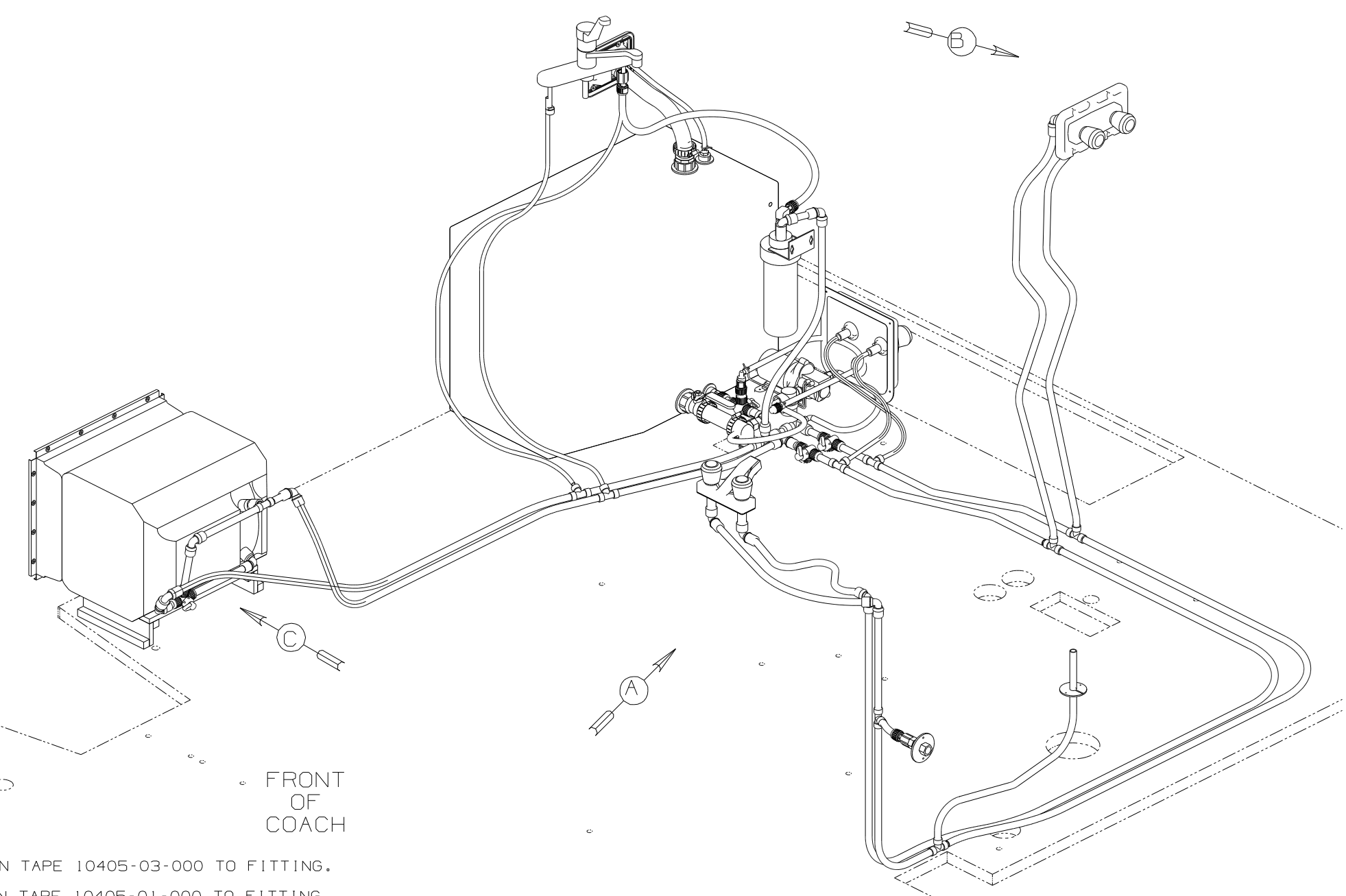

FRONT
OF
COACH

- NOTES:
- 5 ADD TEFLON TAPE 10405-03-000 TO FITTING.
 - 4 ADD TEFLON TAPE 10405-01-000 TO FITTING.
 - 3. ALL TUBING TO BE SECURED AT 1200 INTERVALS MAXIMUM WITH CLAMP 10495-01-000 OR CLIP 9151-01-000 AND SCREW G67-10-12B.
 - 2. TUBING TO BE INSTALLED WITH SUFFICIENT SLOPE TO PROVIDE DRAINAGE TO NEAREST VALVE.
 - 1. PLASTIC FITTINGS TO BE SEALED WITH SEALANT 84456-01-000.

- 29B WATER PURIFIER
- 501 WATER PURIFIER WITHOUT
- 1J4 EXT WASH STATION W/O
- 64R EXTERIOR WASH STATION
- 53F WATER HEATER-ELEC. IGNITION

WINNEBAGO		COPYRIGHT 2006 WINNEBAGO INDUSTRIES, INC.	
DFTR	ORIG. DATE	ALL DIMENSIONS ARE IN MILLIMETERS	
CHKR		FIRST USED	
P.E.		06 325F	
M.E.		UNSPECIFIED TOLERANCES ARE:	
DSNR		MATERIAL:	
		WHOLE DIM (X) :	7
		ONE-PLACE (X.X) :	
		TWO-PLACE (X.XX) :	
		ANGLE :	
THIRD ANGLE PROJECTION		DO NOT SCALE DRAWING	
TITLE: WATER SYSTEM INSTL			
SHEET 1 OF 3	PART NO	153566	REV
REF:	1 6/13/2006		

(X-X)
FOR
WATER
CALLOUTS
SEE DWG NO
116230-01-000

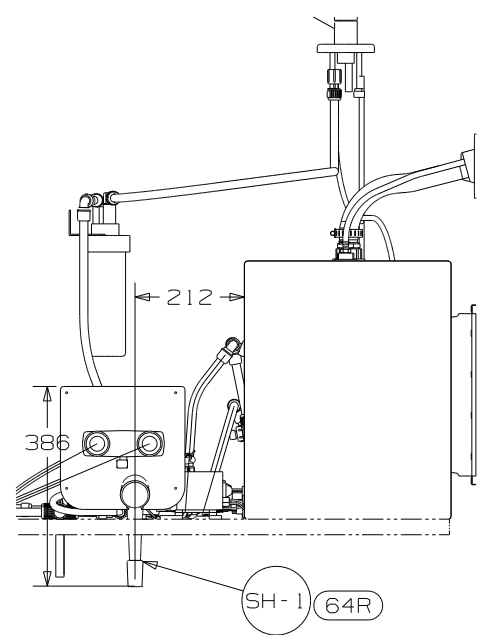

VIEW D
64R

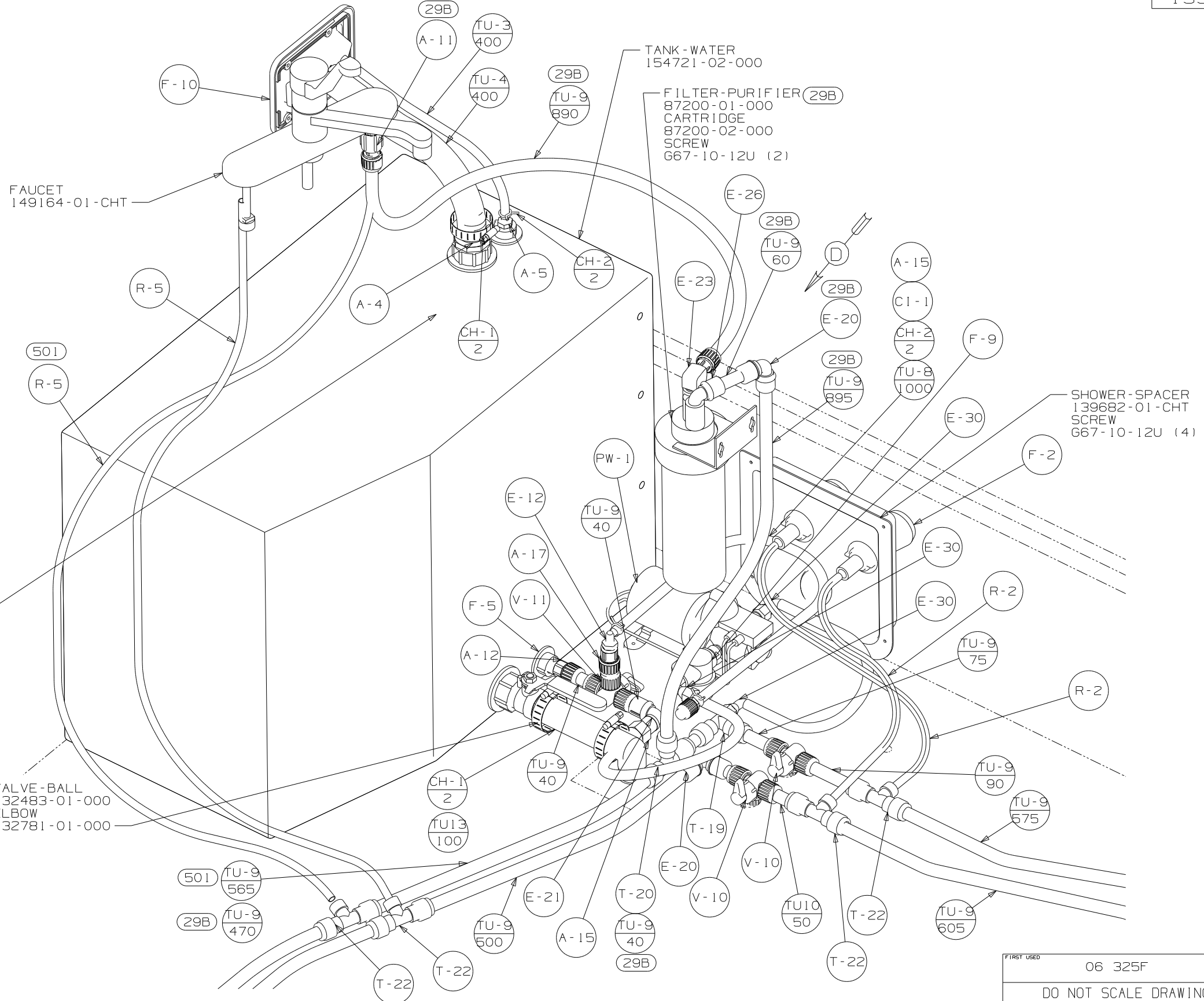

VIEW A

FIRST USED	06 325F		
TITLE	DO NOT SCALE DRAWING		
SHEET 2	PART NO	153566	REV

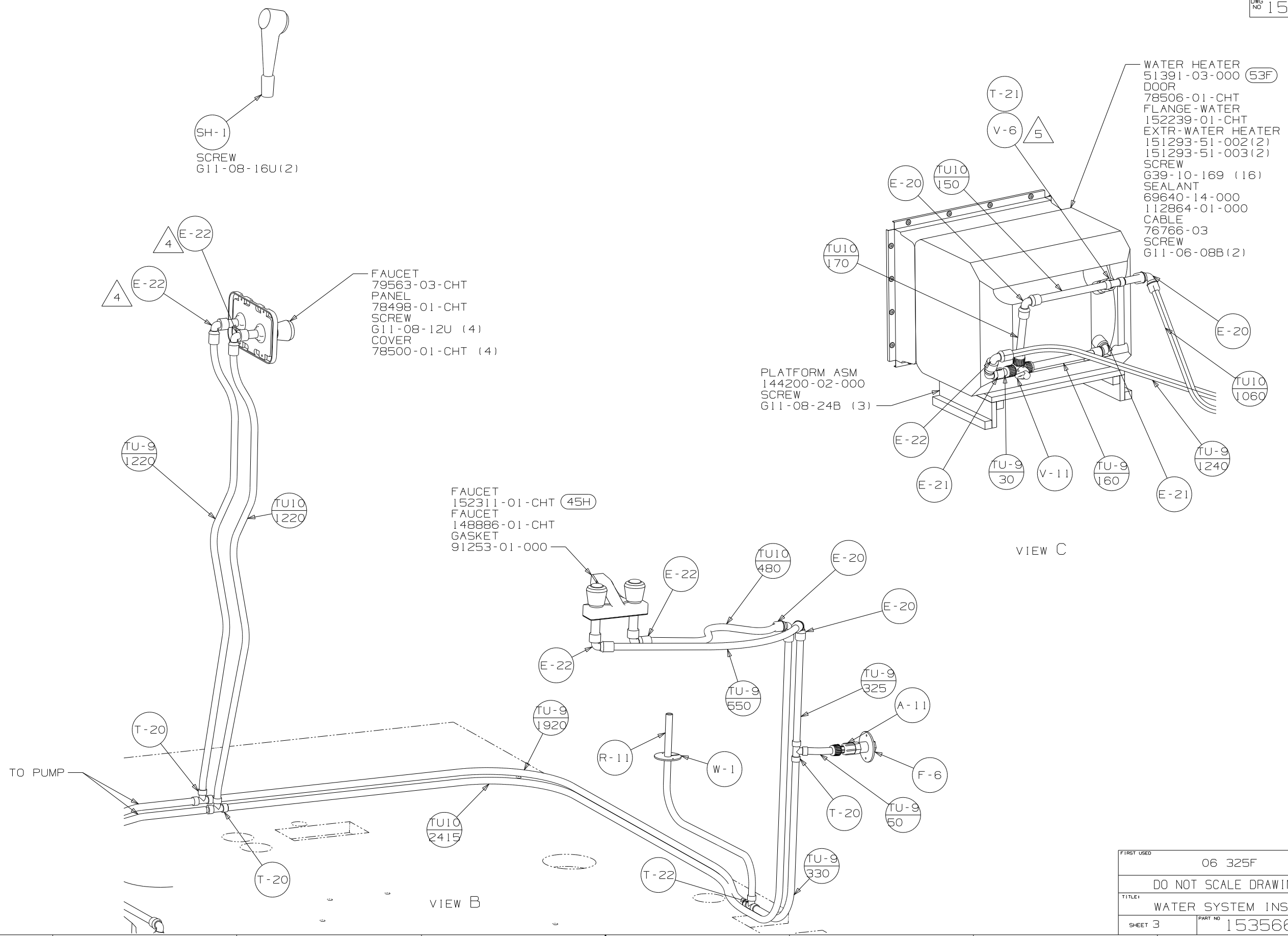

VIEW C

VIEW B

TO PUMP

FIRST USED	06 325F		
TITLE	DO NOT SCALE DRAWING		
TITLE	WATER SYSTEM INSTL		
SHEET 3	PART NO	153566	REV