



DANGER

Danger of electrical shock, burns or death. Always remove all power sources before attempting any repair, service or diagnostic work. Power can be present from shore power, generator, inverter or battery. All power sources must be disabled and secured before performing any service.



CAUTION

If you lack the skills, tools or equipment to perform diagnostic or repair work leave such work to an authorized Winnebago Industries dealer or other qualified shop.

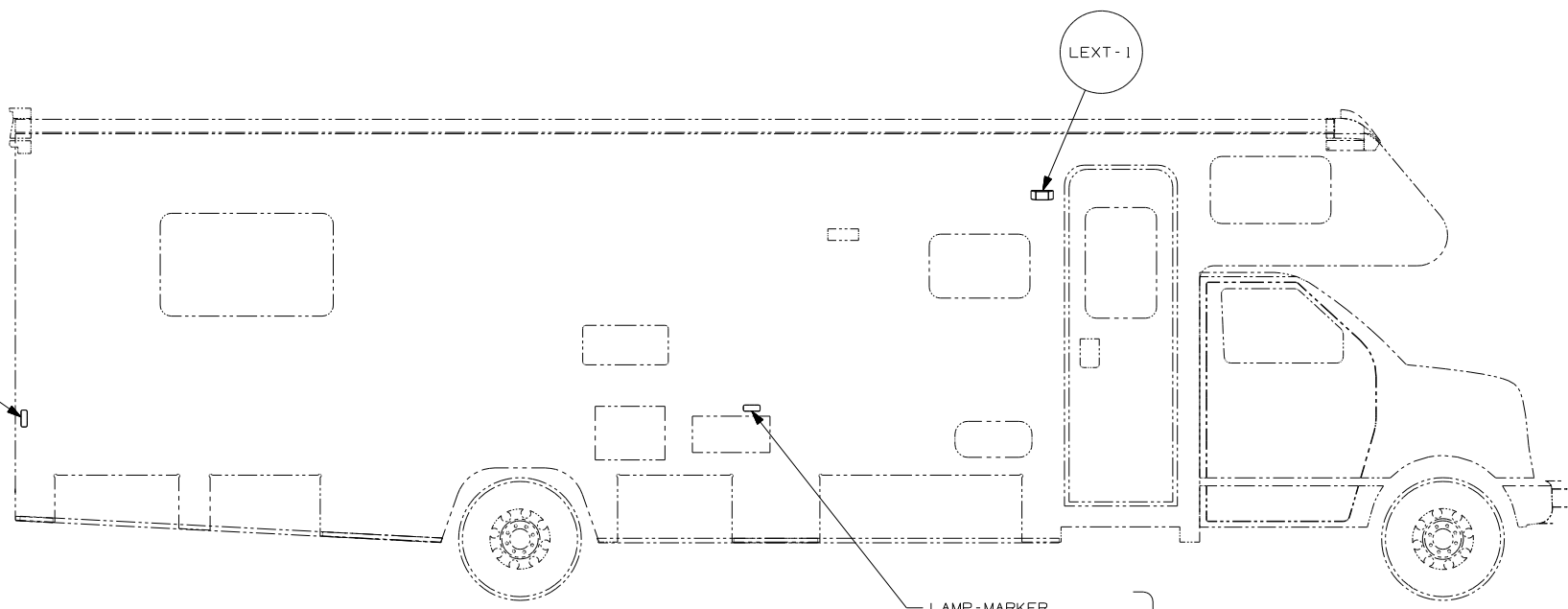

LAMP-MARKER
BASE, SIDEWALL
111102-01-000
LENS-MARKER, RED
111102-03-000
SCREW
G11-08-12T (EXT) (2)
CONNECTOR
58028-01-000 (2)

LAMP-MARKER
BASE, SIDEWALL
111102-01-000
LENS-MARKER, AMBER
111102-02-000
SCREW
G11-08-12T (EXT) (2)
CONNECTOR
58028-01-000 (2)

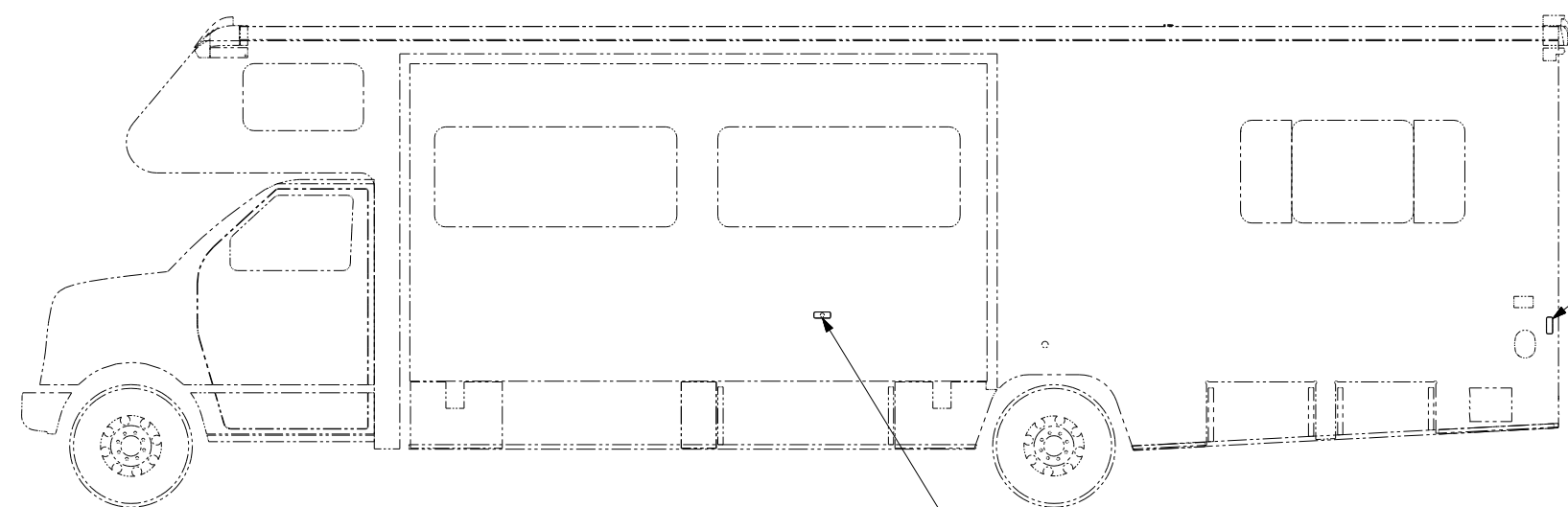

LAMP-MARKER
BASE, SIDEWALL
111102-01-000
LENS-MARKER, RED
111103-03-000
SCREW
G11-08-12T (EXT) (2)
CONNECTOR
58028-01-000 (2)

LAMP-MARKER
BASE, SIDEWALL
111102-01-000
LENS-MARKER, AMBER
111102-02-000
SCREW
G11-08-12T (EXT) (2)
CONNECTOR
58028-01-000 (2)

265 CODES/STANDARDS-CSA/CMVSS
1B1 CODES/STANDARDS USA
1B1 265



DFTR	ORIG. DATE
CHKR	ALL DIMENSIONS ARE IN MILLIMETERS
P.E.	
M.E.	FIRST USED
DSNR	05 300 SERIES
UNSPECIFIED TOLERANCES ARE:	MATERIAL:
HOLE DIM (X)	:
ONE-PLACE (X.X)	:
TWO-PLACE (X.XX)	:
ANGLE	:
THIRD ANGLE PROJECTION	

DO NOT SCALE DRAWING
TITLE: WIRING INSTL-EXTERIOR LAMPS
SHEET 1 OF 2 PART NO 148499

FOR ELECTRICAL TORQUE SPECIFICATIONS SEE DWG NO. 128783-01-000

FOR ELECTRICAL CALLOUTS SEE DWG NO. 121339-01-000

2 USED ONLY WITH 331C, 331T, 331SC, 331ST & 332G.
1 ON 329B, COVER WIRES WITH TAPE 8363-01-000 AFTER CONNECTIONS ARE MADE.

NOTES:

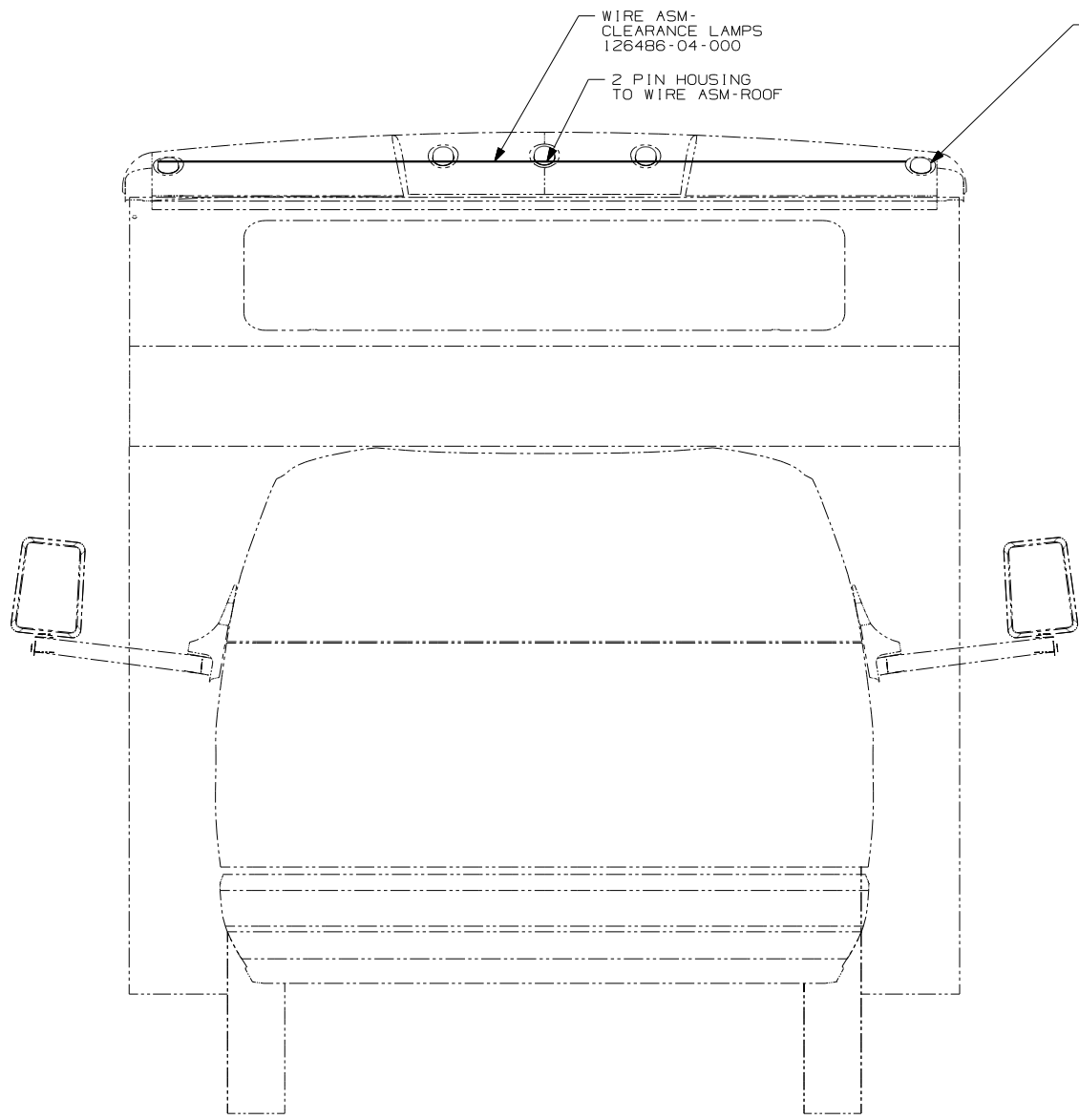

LAMP ASM-CLEARANCE, AMBER
138996-01-000 (5)
BRACKET-LAMP CLEARANCE
138996-03-000 (5)
SCREW
G11-06-08T (EXT) (10)

LAMP ASM-CLEARANCE, RED
138996-02-000 (5)
BRACKET-LAMP CLEARANCE
138996-03-000 (5)
SCREW
G11-06-08T (10)

WIRE ASM-CLEARANCE LAMPS
126486-04-000

WIRE ASM-BACKWALL CONNECTS
TO WIRE ASM-ROOF

TAILLAMP ASM-
81638-01-000 (2)
SCREW
G11-08-12T (16)
POD TAILLAMP
103355-02-CHT
SCREW
G67-10-129 (8)
CONNECTOR
58028-01-000
(8)
SEALER-TAPE
6964-21-000 (3,4)

BRACKET-LICENSE
66432-03-000
SCREW
G67-10-129 (2)
LIGHT-LICENSE
66432-02-000
SCREW
G39-08-12T (EXT) (2)
CONNECTOR
58028-01-000 (2)

6 PIN HOUSING
TO WIRE ASM-
TAILLAMP EXTENSION

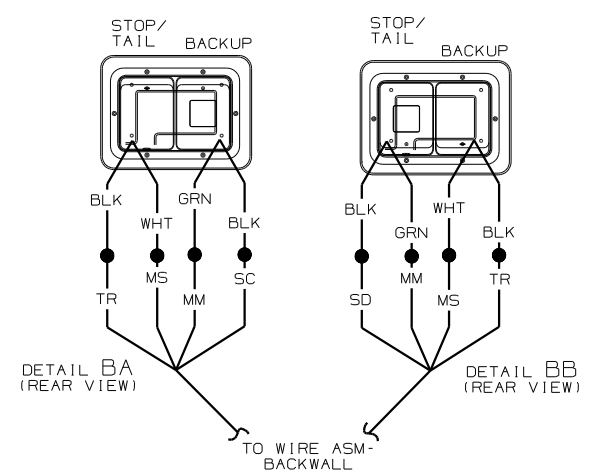
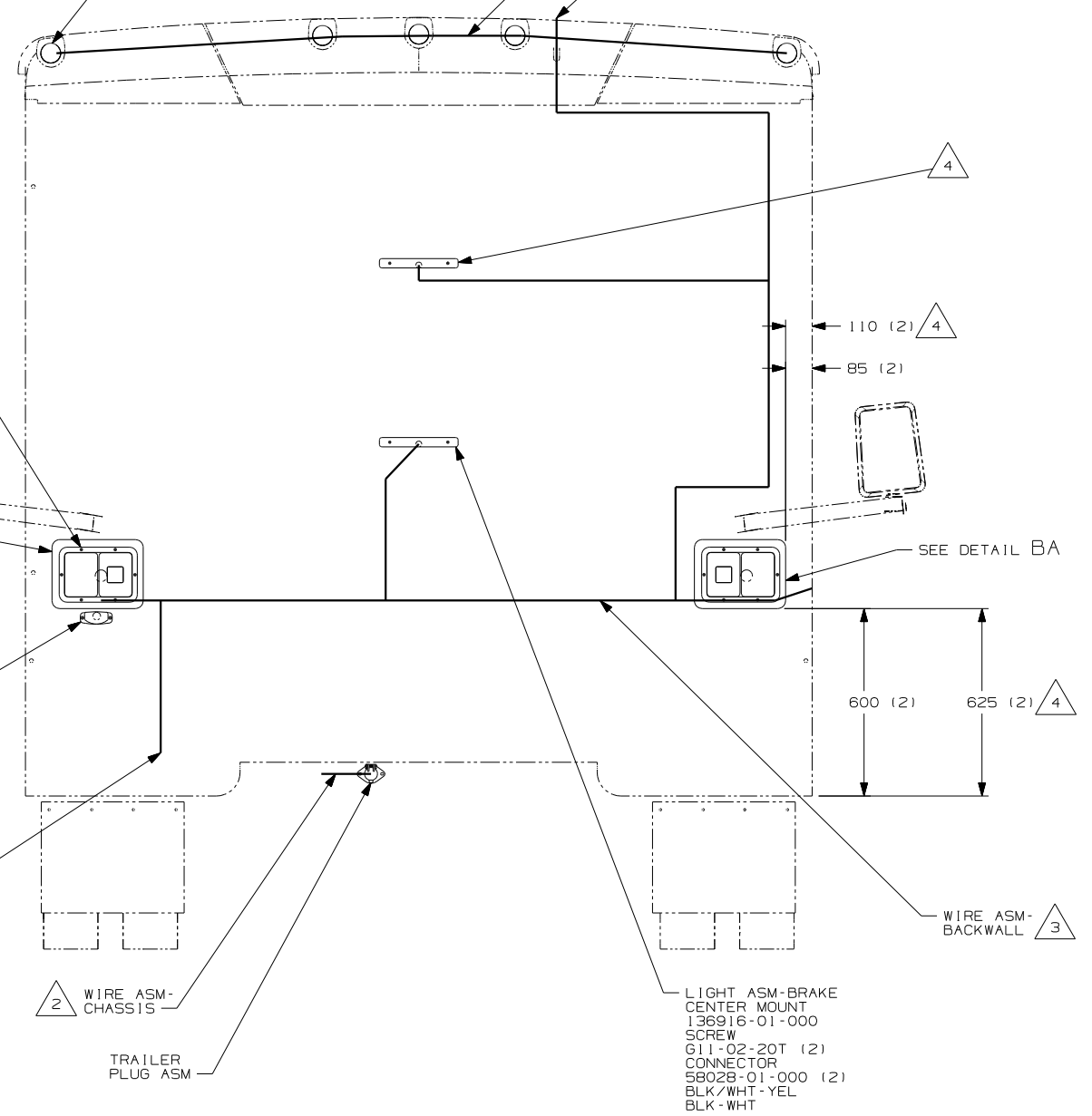

- 4 LIGHT ASM IS MOUNTED IN THIS LOCATION ON THE 326A.
- 3 LOCATED IN BACKWALL ASSEMBLY
- 2 SECURE WIRE BELOW COACH WITH CLAMP 10495-01-000 AND SCREW G67-10-12B.

NOTES:
1. CONNECTOR-PLUG, TRAILER 113589-01-000 TO BE SUPPLIED LOOSE IN COACH WITH TRAILER TOW PACKAGE.

FOR ELECTRICAL TORQUE SPECIFICATIONS SEE DWG NO. 128783-01-000

FOR ELECTRICAL CALLOUTS SEE DWG NO. 121339-01-000

265 CODES/STANDARDS-CSA/CMVSS
1B1 CODES/STANDARDS USA
1B1 265

FIRST USED	
05 300 SERIES	
DO NOT SCALE DRAWING	
TITLE: WIRING INSTL-EXTERIOR LAMPS	
SHEET 2	PART NO 148499