



DANGER

Danger of electrical shock, burns or death. Always remove all power sources before attempting any repair, service or diagnostic work. Power can be present from shore power, generator, inverter or battery. All power sources must be disabled and secured before performing any service.



CAUTION

If you lack the skills, tools or equipment to perform diagnostic or repair work leave such work to an authorized Winnebago Industries dealer or other qualified shop.

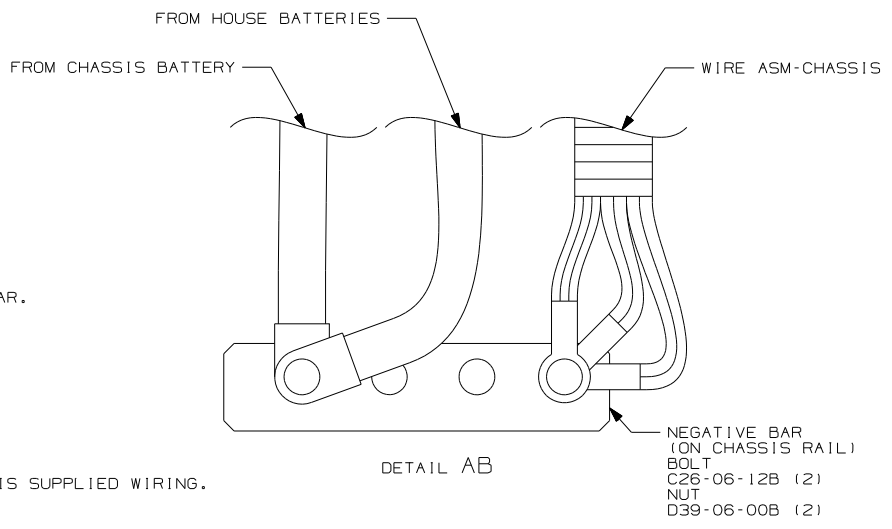
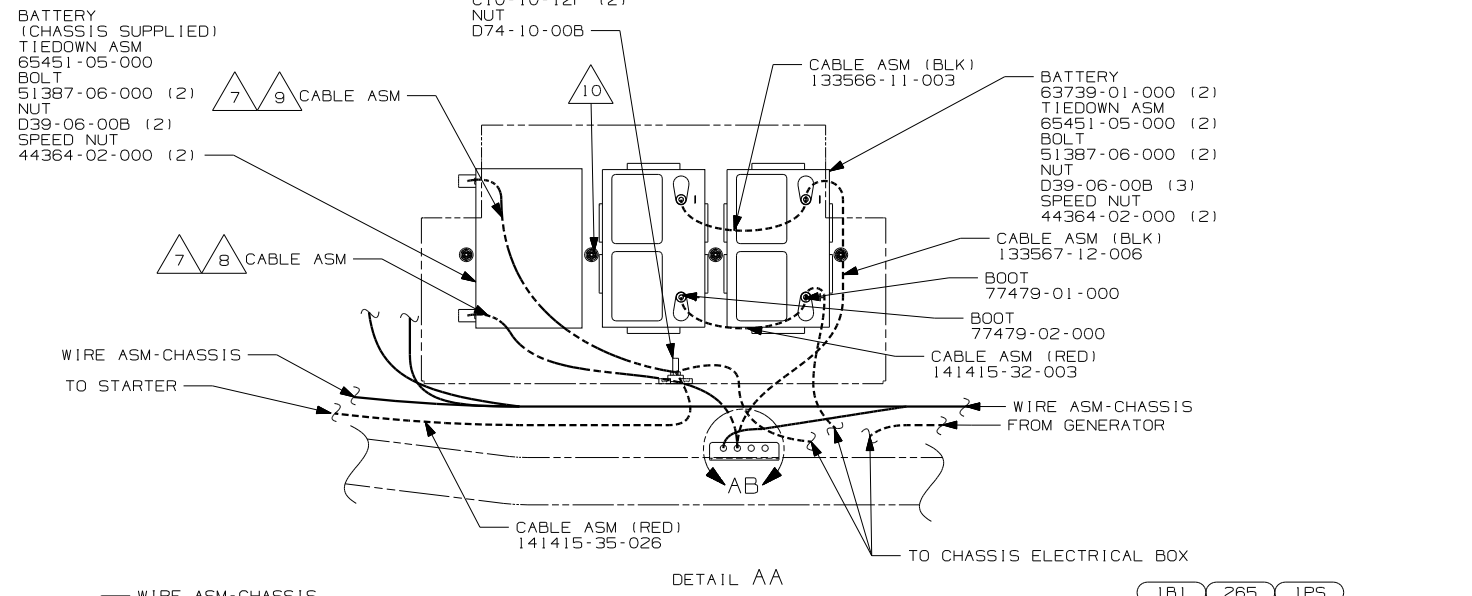
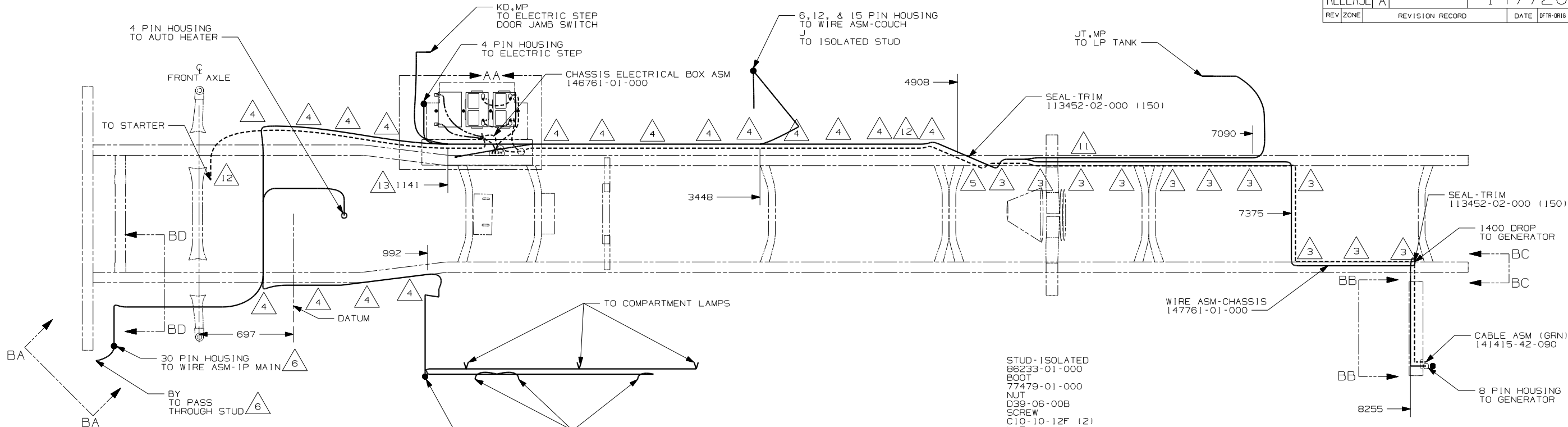

- 12 SECURE SO WIRES DO NOT CONTACT EXHAUST.
- 11 ROUTE WIRES & CABLE OVER SPRING HANGER AT THIS POINT.
- 10 USE TWO NUTS HERE TO ACCOUNT FOR BATTERY HEIGHT DIFFERENCE.
- 9 LOCATE CHASSIS SUPPLIED RED WIRES TO ISOLATED STUD, CUT AND ADD TERMINALS 68070-01-000 (2) TO THE CUT ENDS.
- 8 LOCATE CHASSIS SUPPLIED GROUND WIRES TO GROUND STUD, CUT AND ADD TERMINALS 8348-01-000 (2) TO THE CUT ENDS.
- 7 SUPPLIED WITH CHASSIS.
- 6 SEE WIRING INSTL-FRONT END FOR ADDITIONAL INFORMATION.
- 5 ROUTE WIRES & CABLE INSIDE CHASSIS RAIL AT THIS POINT AND TO THE REAR.
- 4 CLAMP 83610-03-000, SCREW G39-08-12B.
- 3 CLAMP 83610-01-000, SCREW G39-08-12B.

2. SECURE CONDUIT 41953-09, -10, -11, -13, AND -14 OVER ALL WIRES IN CONTACT WITH SHARP EDGES.

1. LEGEND: — WINNEBAGO: - - - - - CABLE: - - - - - CHASSIS SUPPLIED WIRING.

NOTES:

265 CODES/STANDARDS - CSA/CMVSS
 IPS WORKHORSE 22,000#-22.5 TIRE
 IBI CODES/STANDARDS - USA

FOR ELECTRICAL TORQUE SPECIFICATIONS SEE DWG NO. 128783-01-000

FOR ELECTRICAL CALLOUTS SEE DWG NO. 121339-01-000

IBI 265 IPS

WINNEBAGO COPYRIGHT 2004 WINNEBAGO INDUSTRIES, INC.

DFTR	ORIG. DATE
CHKR	ALL DIMENSIONS ARE IN MILLIMETERS
P.E.	
M.E.	FIRST USED
DSNR	04 G37B

UNSPECIFIED TOLERANCES ARE: MATERIAL:

WHOLE DIM (X) : *
 ONE-PLACE (X.X) : *
 TWO-PLACE (X.XX) : *
 ANGLE : *

THIRD ANGLE PROJECTION

DO NOT SCALE DRAWING

TITLE: WIRING INSTL-CHASSIS

SHEET 1 OF 2 PART NO 147720

REF: 1 1/7/2004

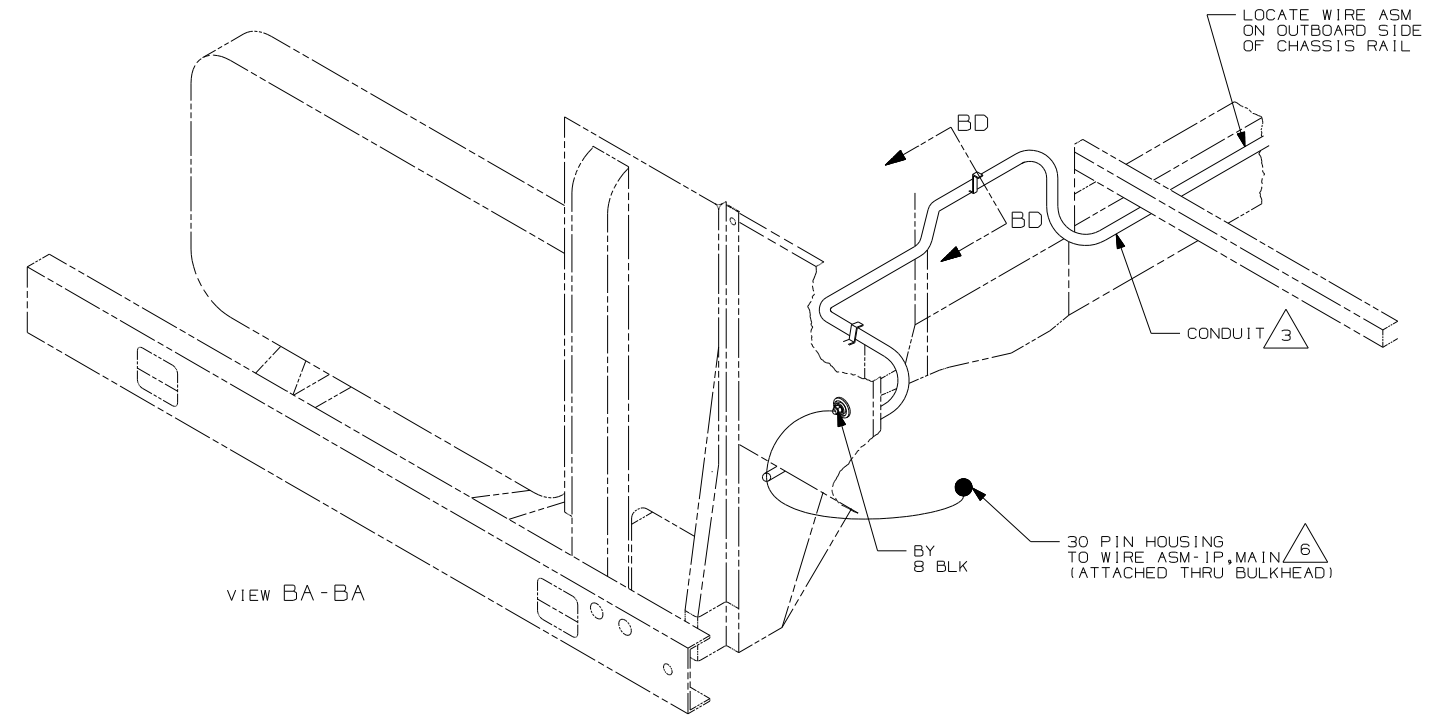
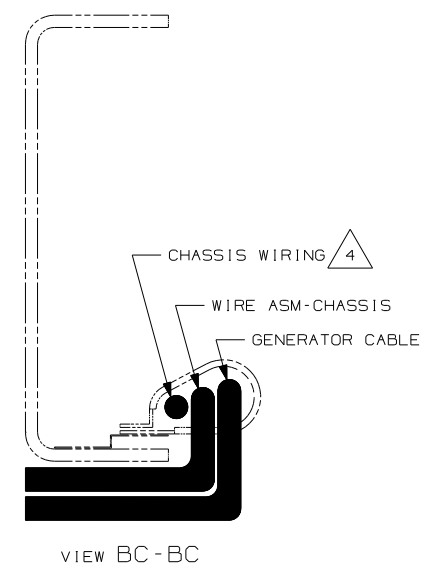
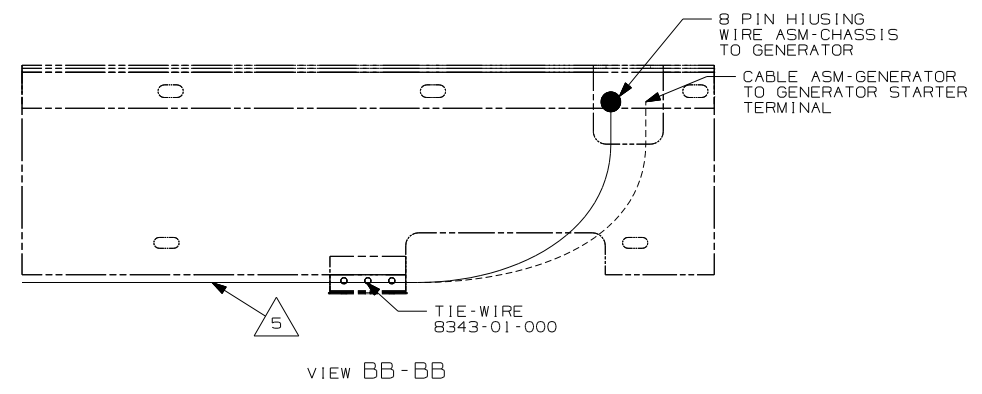
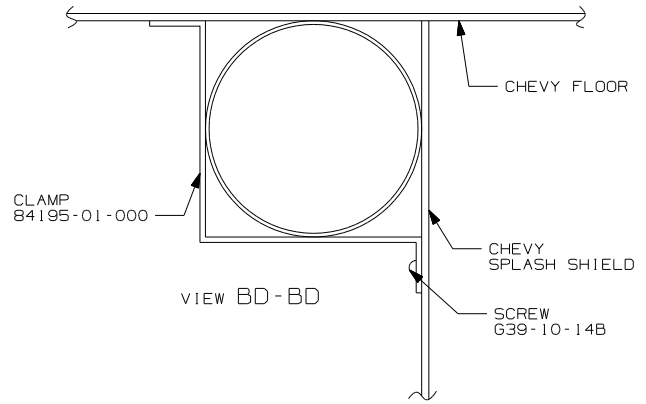

- 6 SEE WIRING INSTL-FRONT END FOR ADDITIONAL INFORMATION.
- 5 SECURE SO WIRES DO NOT CONTACT EXHAUST.
- 4 SUPPLIED WITH CHASSIS.
- 3 COVER WITH CONDUIT 41953-10-000 AND 41953-11-000 AS REQUIRED.

2. SECURE CONDUIT 41953-09, -10, -11, -13, AND -14 OVER ALL WIRES IN CONTACT WITH SHARP EDGES.

1. LEGEND: — WINNEBAGO: - - - - - CABLE: - - - - - CHASSIS SUPPLIED WIRING.

- 265 CODES/STANDARDS - CSA/CMVSS
- IPS WORKHORSE 22,000#-22.5 TIRE
- IB1 CODES/STANDARDS - USA

FOR ELECTRICAL TORQUE SPECIFICATIONS SEE DWG NO. 128783-01-000

FOR ELECTRICAL CALLOUTS SEE DWG NO. 121339-01-000

FIRST USED	
04 G37B	
DO NOT SCALE DRAWING	
TITLE: WIRING INSTL-CHASSIS	
SHEET 2	PART NO 147720