



DANGER

Danger of electrical shock, burns or death. Always remove all power sources before attempting any repair, service or diagnostic work. Power can be present from shore power, generator, inverter or battery. All power sources must be disabled and secured before performing any service.



CAUTION

If you lack the skills, tools or equipment to perform diagnostic or repair work leave such work to an authorized Winnebago Industries dealer or other qualified shop.

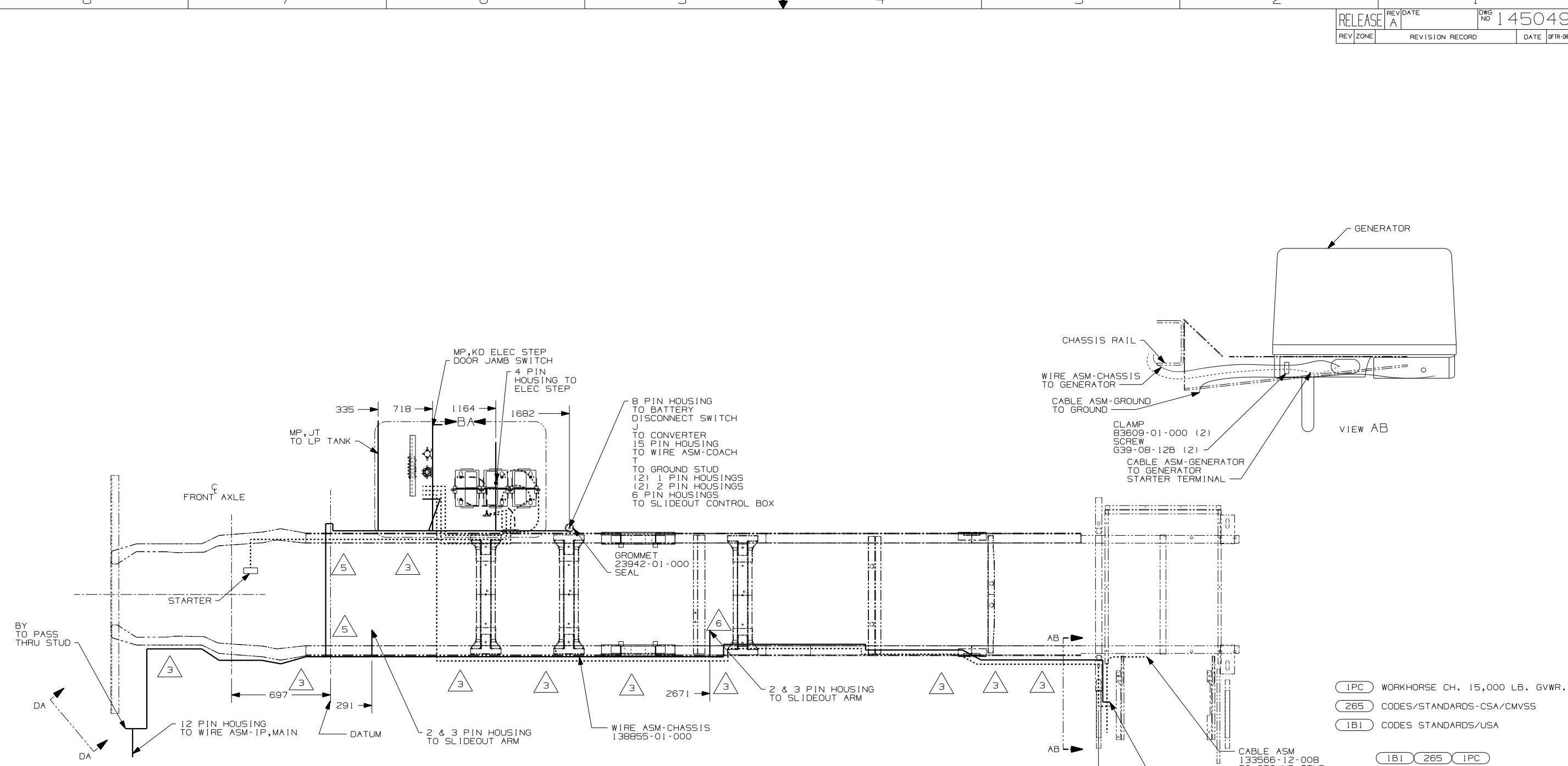

- IPC WORKHORSE CH. 15,000 LB. GVWR.
- 265 CODES/STANDARDS-CSA/CMVSS
- 1B1 CODES STANDARDS/USA

1B1 265 IPC



DFT	ORIG. DATE
CHKR	ALL DIMENSIONS ARE IN MILLIMETERS
P.E.	
M.E.	FIRST USED
DSNR	04 D27C

UNSPECIFIED TOLERANCES ARE:	MATERIAL:
WHOLE DIM (X)	: 1
ONE-PLACE (X.X)	: 1.5
TWO-PLACE (X.XX)	: 0.50
ANGLE	: 1°

THIRD ANGLE PROJECTION

DO NOT SCALE DRAWING
TITLE: WIRING INSTL-CHASSIS
SHEET 1 of 3 PART NO 145049

FOR ELECTRICAL TORQUE SPECIFICATIONS SEE DWG NO. 128783-01-000

FOR ELECTRICAL CALLOUTS SEE DWG NO. 121339-01-000

- NOTES:
- 6 ROUTE WIRES ON TOP OF CHASSIS RAIL & COIL EXCESS WIRE HERE.
 - 5 CLAMP 10497-03-000, SCREW 639-08-12B.
 - 4 USE 116673-01-000 TO SECURE WIRES THRU HOLES IN CHASSIS FRAME.
 - 3 CLAMP 83610-01-000, SCREW 639-08-12B.
 - 2 SECURE CONDUIT 41953-01-000, 41953-02-000 AND 41953-03-000 OVER ALL WIRES IN CONTACT WITH SHARP EDGES.
 - 1 LEGEND: — WINNEBAGO, CABLE, - - - - - CHASSIS SUPPLIED.

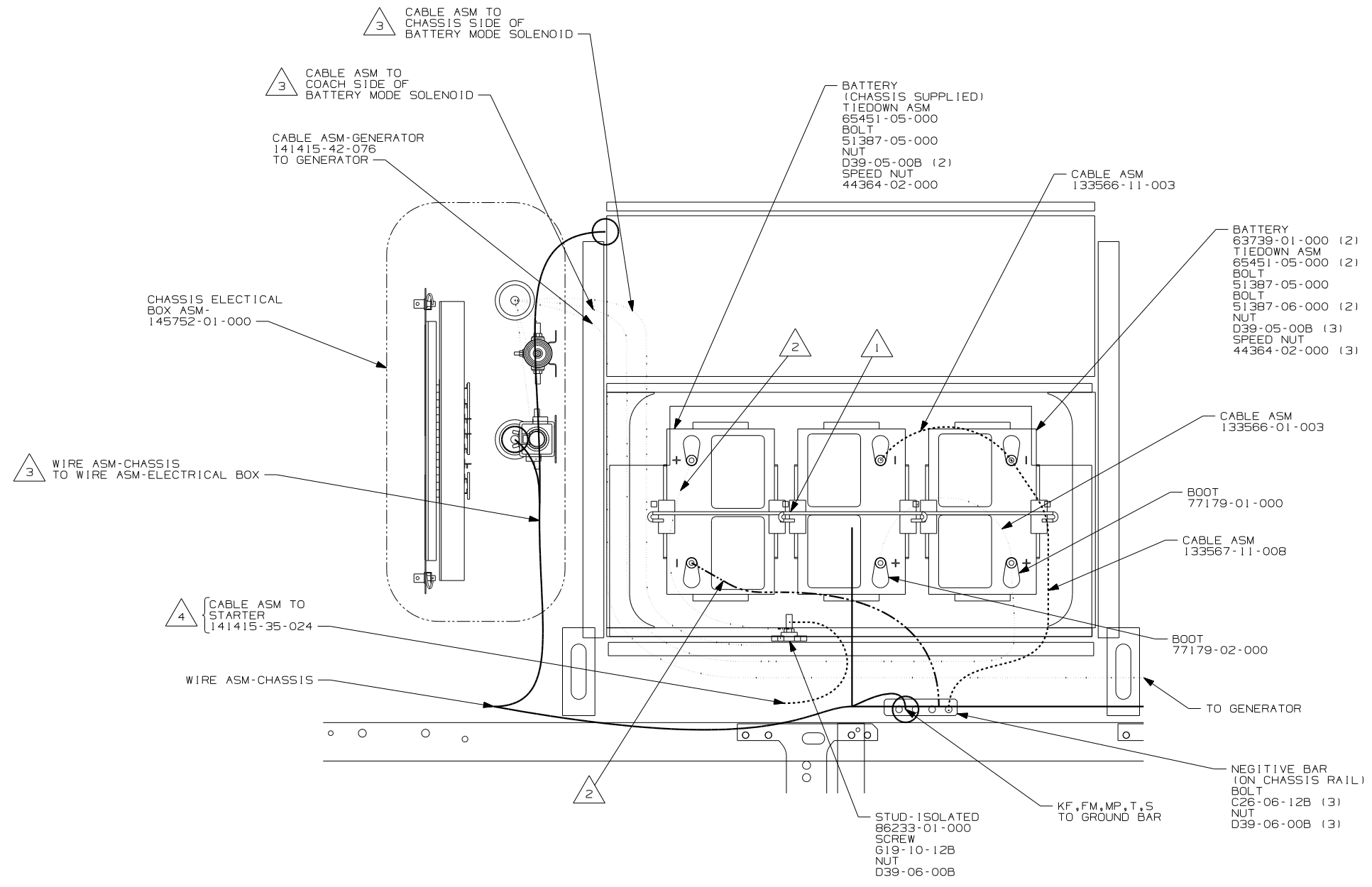

VIEW BA

- 4 BATTERY CABLES MUST BE INSTALLED TO STARTER MOTOR BEFORE ENGINE WIRING HARNESS AND ROUTED IN SUCH A MANNER AS TO PREVENT ANY POSSIBLE DEGRADATION FROM THE EXHAUST SYSTEM.
- 3 SEE CHASSIS ELECTRICAL BOX FOR ADDITIONAL INFORMATION.
- 2 TRIM CABLE TO 500MM, ADD TERMINALS 8348-01-000 (2), INCLUDE ALL SMALL GROUND WIRES.
- 1 USE TWO NUTS HERE TO ACCOUNT FOR BATTERY HEIGHT DIFFERENCE.

NOTES:

- IPC WORKHORSE CH. 15,000LB. GVWR
- 265 CODES/STANDARDS-CSA/CMVSS
- 1B1 CODES/STANDARDS USA

FIRST USED	04 D27C
TITLE	DO NOT SCALE DRAWING
	WIRING INSTL-CHASSIS
SHEET 2	PART NO 145049

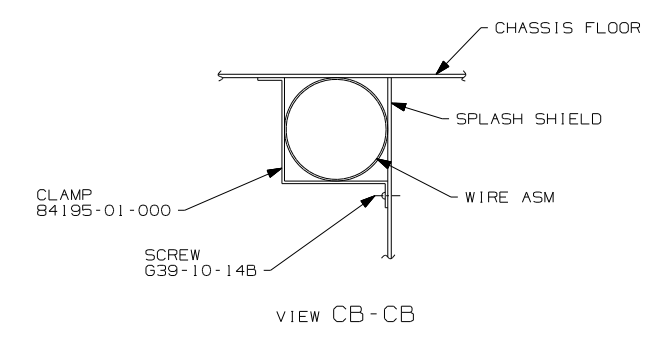
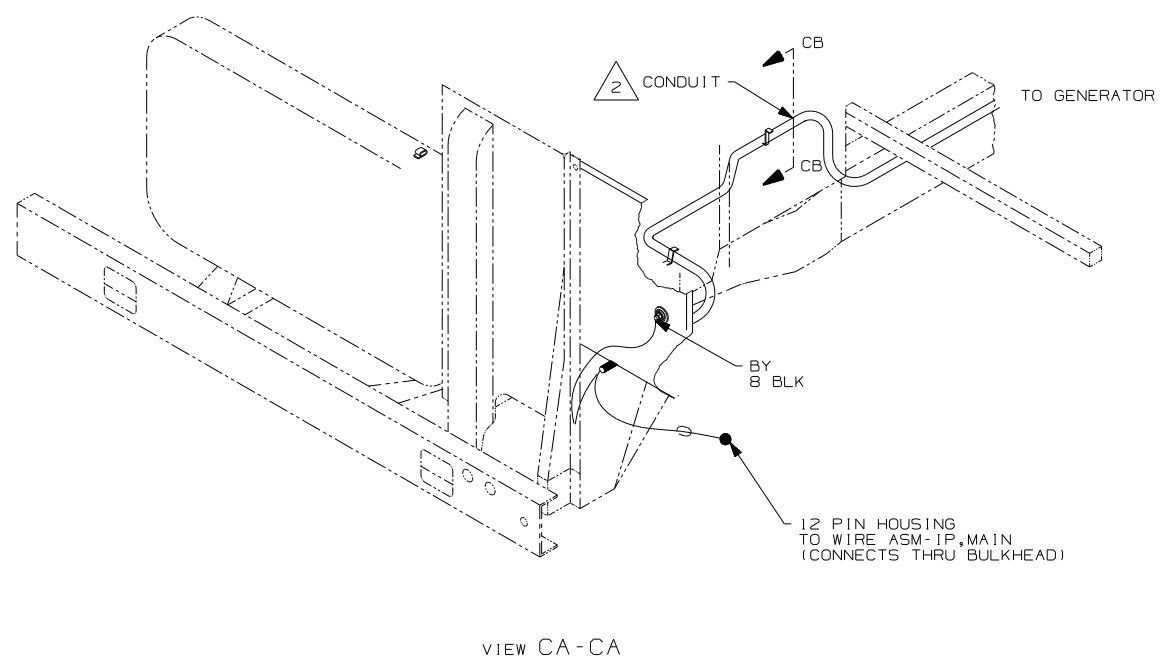

- NOTES:
- 3 SECURE WITH SOLENOID MOUNTING SCREW.
 - 2 COVER WITH CONDUIT 41953-10-000 AND 41953-11-000 AS REQUIRED.
 - 1. CUT OFF EXCESS END OF WIRE TIE.

- IPC WORKHORSE CH. 15,000 LB. GVWR.
- 265 CODES/STANDARDS-CSA/CMVSS
- 1B1 CODES STANDARDS/USA

IPC 1B1 265

FIRST USED	04 D27C
DO NOT SCALE DRAWING	
TITLE:	WIRING INSTL-CHASSIS
SHEET 3	PART NO 145049

FOR ELECTRICAL TORQUE SPECIFICATIONS SEE DWG NO. 128783-01-000

FOR ELECTRICAL CALLOUTS SEE DWG NO. 121339-01-000

