

- (1B1) CODES/STANDARDS USA
- (265) CODES/STANDARDS-CSA/CMVSS
- (43M) TOILET PORCLAIN-ELONGATED
- (430) TOILET-PORCLAIN
- (43E) SHOWER HEAD-FIXED
- (WDL) WINNEBAGO DELUXE UPGRADE
- (ITA) ITASCA ONLY
- (WIN) WINNEBAGO ONLY

- NOTES:
7. SEE DRAWING 61607-01-000 FOR INSTL OF GROMMETS.
  6. VENT PIPE MUST PROECT 51 MIN AND 64 MAX ABOVE ROOF FOR PROPER FIT AND FUNCTION.
  5. SEAL AROUND SHOWER WITH SILICONE.
  4. ALL EXTERIOR OPENINGS AROUND PIPE TO BE SEALED WITH 110744-01-000.
  3. ALL PIPE AND FITTINGS TO BE ASSEMBLED WITH SOLVENT 4020-01-000.
  2. SLOPE OF TRAP ARM MUST BE 6 PER 305 mm.
  1. SLOPE OF HORIZONTAL PIPING TO BE 6 PER 305 mm.

<b>WINNEBAGO</b>		COPYRIGHT 2002 WINNEBAGO INDUSTRIES, INC.	
D/FR	ORIG. DATE	ALL DIMENSIONS ARE IN MILLIMETERS	
CHKR		FIRST USED	
P.E.		03 P36L	
M.E.		UNSPECIFIED TOLERANCES ARE:	
DSNR		MATERIAL:	
		WHOLE DIM (X) :	7
		ONE-PLACE (X.X) :	
		TWO-PLACE (X.XX) :	
		ANGLE :	
THIRD ANGLE PROJECTION		DO NOT SCALE DRAWING	
TITLE:		DRAINAGE SYSTEM INSTL	
SHEET 1 OF 4	PART NO	141644	

(X-X)  
FOR  
DRAINAGE  
CALLOUTS  
SEE DWG NO  
116229-01-000

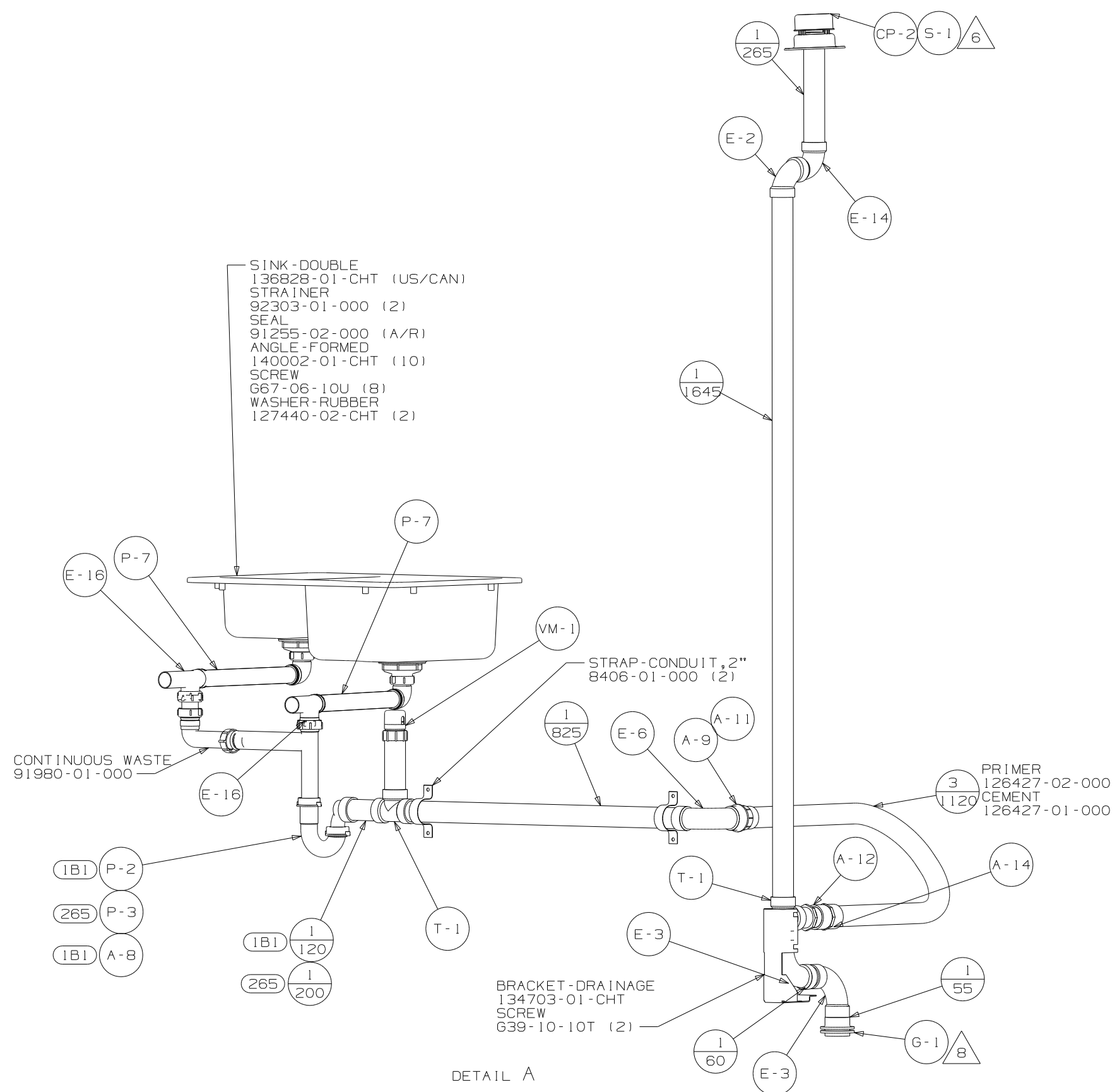

FIRST USED	03 P36L
DO NOT SCALE DRAWING	
TITLE	DRAINAGE SYSTEM INSTL
SHEET 2	PART NO 141644

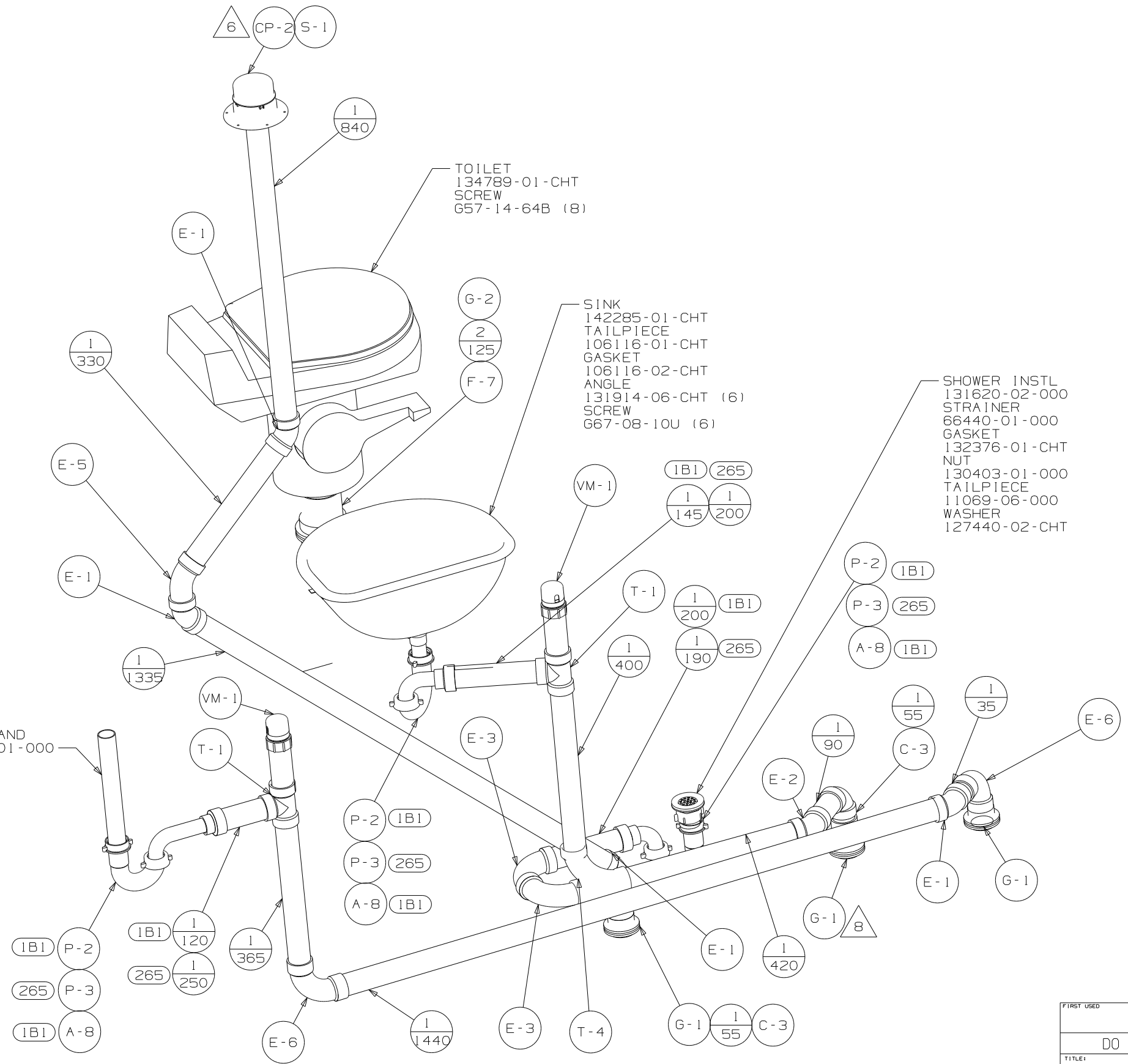

TOILET  
134789-01-CHT  
SCREW  
G57-14-64B (8)

SINK  
142285-01-CHT  
TAILPIECE  
106116-01-CHT  
GASKET  
106116-02-CHT  
ANGLE  
131914-06-CHT (6)  
SCREW  
G67-08-10U (6)

SHOWER INSTL  
131620-02-000  
STRAINER  
66440-01-000  
GASKET  
132376-01-CHT  
NUT  
130403-01-000  
TAILPIECE  
11069-06-000  
WASHER  
127440-02-CHT

PIPE-STAND  
130234-01-000

DETAIL B

FIRST USED	03 P36L
DO NOT SCALE DRAWING	
TITLE	DRAINAGE SYSTEM INSTL
SHEET 3	PART NO 141644

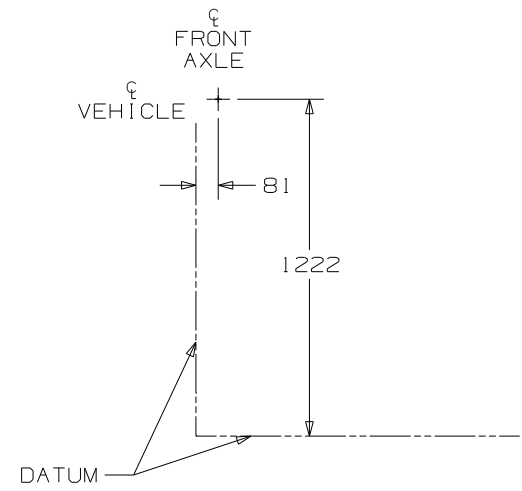

PLATFORM ASM  
126714-25-000

PLATFORM ASM  
126714-24-000

BRACKET  
94756-02-CHT (4)  
SCREW  
G39-10-10T (12)

PLATFORM ASM  
126714-26-000

DETAIL C

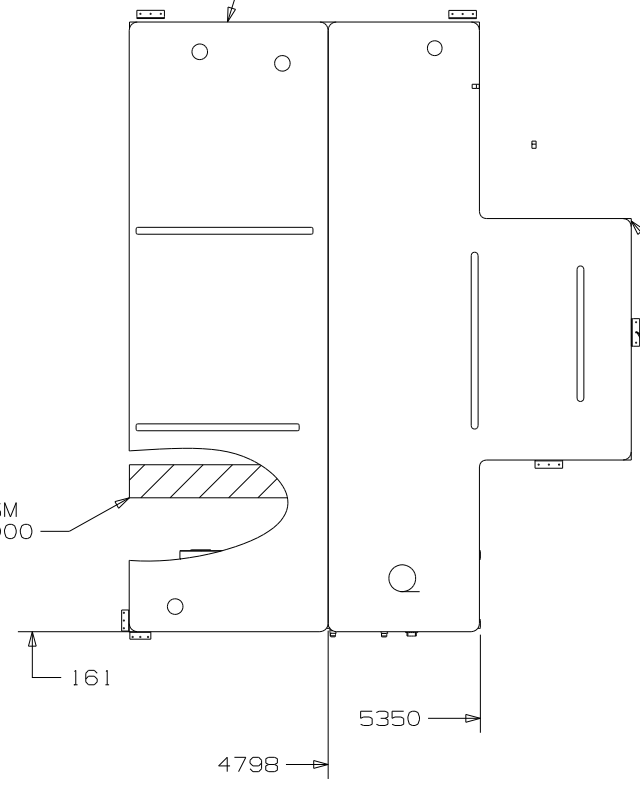

TANK - HOLDING  
132407-02-000

TANK - HOLDING  
132408-02-000

BRACKET  
126796-04-CHT  
SCREW  
G39-10-10T (24)

SUPPORT ASM  
133839-01-CHT (2)

N-3

E-18

2/70

C-2

V-11 H-1

2/70

C-2

E-18

N-3

DETAIL D

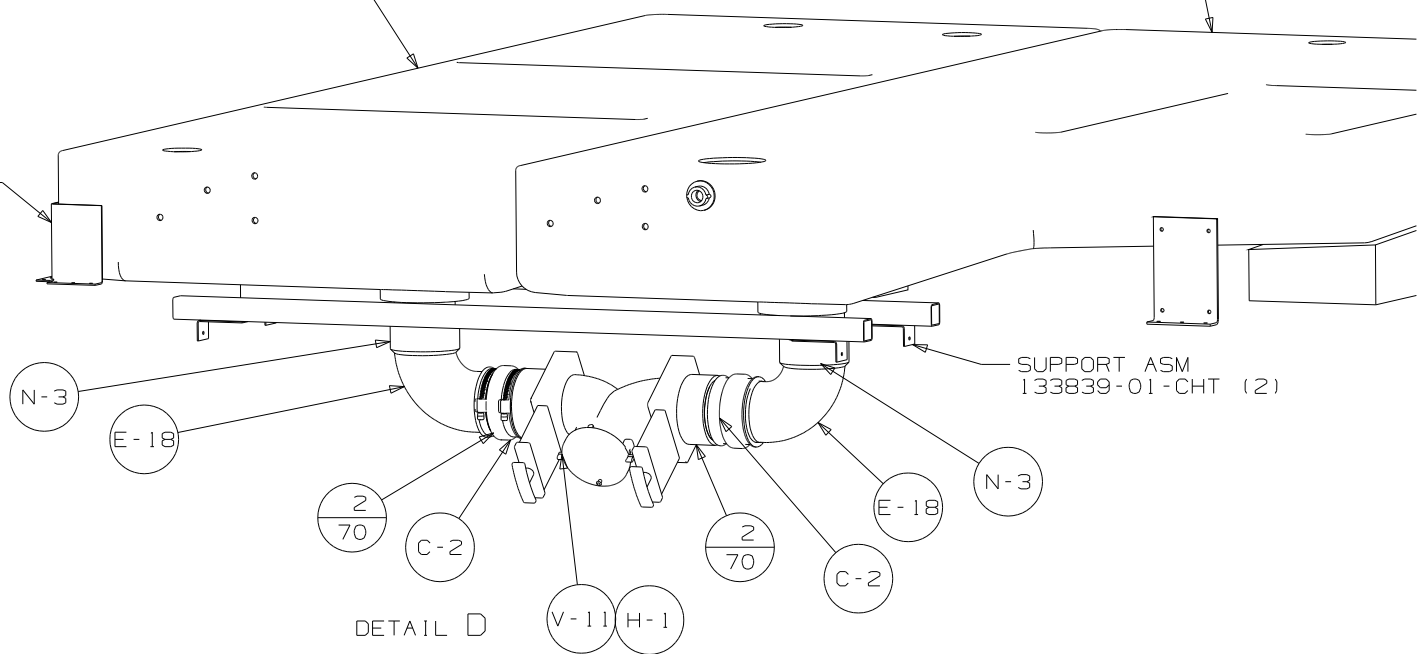

FIRST USED	03 P36L
DO NOT SCALE DRAWING	
TITLE	DRAINAGE SYSTEM INSTL
SHEET 4	PART NO 141644

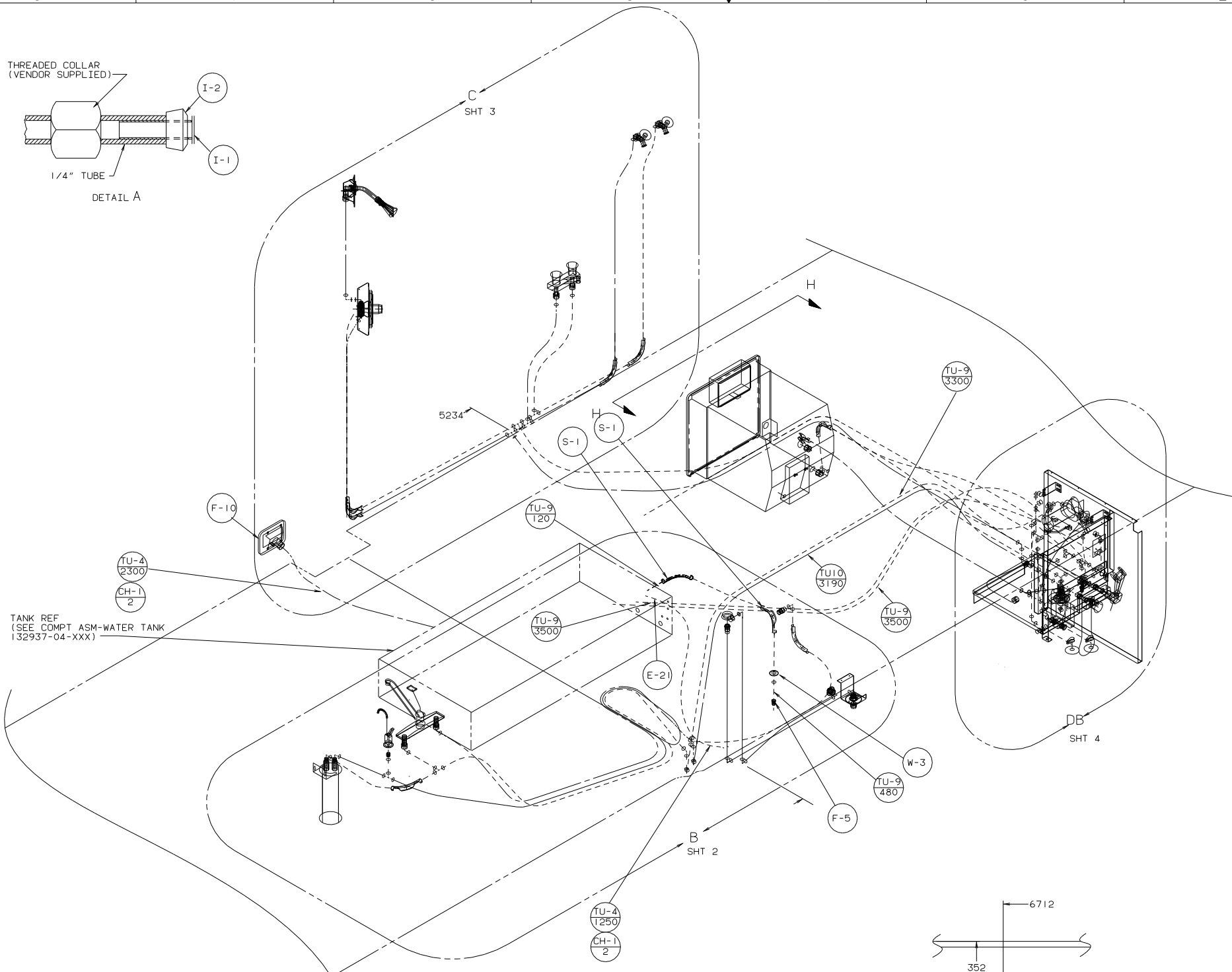
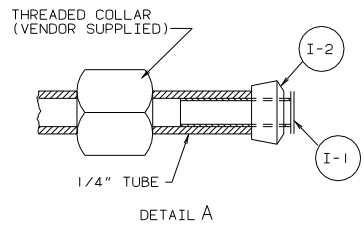

TANK REF  
(SEE COMPT ASM-WATER TANK  
132937-04-XXX)

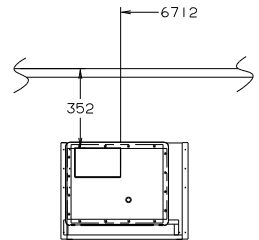

- 10. APPLY DECAL INSIDE OF UPPER SHOWER HEAD HOLDER TO RETAIN HAND SHOWER UNIT INSIDE OF HOLDER.
  - 9. WRAP WITH TEFLON TAPE 10405-03-000 TO FITTINGS.
  - 8. WRAP WITH TEFLON TAPE 10405-02-000 TO FITTINGS.
  - 7. WRAP WITH TEFLON TAPE 10405-01-000 MINIMUM THREE WRAPS.
  - 6. FLUSHING SYSTEM REQUIRES 125697-06-000 INSTRUCTION SHEET.
  - 5. CLAMPS MUST BE ON BARBS.
  - 4. USE DETAIL "A" IN THIS AREA.
3. ALL TUBING TO BE SECURED AT 1200 INTERVALS MAXIMUM WITH CLAMP 10495-01-000 OR CLIP 9151-01-000 AND SCREW G67-10-12B.
  2. TUBING TO BE INSTALLED WITH SUFFICIENT SLOPE TO PROVIDE DRAINAGE TO NEAREST VALVE.
  1. PLASTIC FITTINGS TO BE SEALED WITH SEALANT 84456-01-000.

NOTES:

- (9B1) SHOWER PACKAGE
- (44F) COUNTERTOP-SOL. SURFACE-BATH
- (79W) REFRIGERATOR-4 DOOR
- (43A) SHOWER HEAD-FIXED
- (43H) SHOWER HEAD-HAND HELD
- (21T) WASHER/DRYER WITHOUT
- (54E) WASHER/DRYER
- (21M) WASHER/DRYER PREP
- (29B) WATER PURIFIER
- (15U) REFRIGERATOR/FRZR W/ICEMAKER

LEGEND		COPYRIGHT 2002 WINNEBAGO INDUSTRIES, INC. <b>WINNEBAGO</b> 03 P36L	
HOT	---	DATE	UNSPECIFIED TOLERANCES ARE:
COLD	----	DATE	WHOLE DIM (XX) ± .7
		DATE	ONE-PLACE (X.X) ± .1
		DATE	TWO-PLACE (X.XX) ± .05
		DATE	ANGLE ± .1
		DATE	THIRD ANGLE PROJECTION
		DATE	
FOR WATER CALLOUTS SEE DWG NO. 116230-01-000		TITLE: WATER SYSTEM INSTL	
LAYOUT NO. P36L	SCALE: NONE	DO NOT SCALE DRAWINGS	SHEET NO. 141645
ALL DIMENSIONS ARE IN MILLIMETERS		SHEET 1 OF 4	REF: 139739   07/12/02

TO WATER CENTER

TO REFRIGERATOR

CHECK VALVE  
125697-03-000

△ BREAKER-VACUUM  
125697-04-000  
(MUST BE MOUNTED ABOVE  
TOILET FLOOD LEVEL)

FAUCET-GALLEY, SGL CONTROL  
141432-01-CHT

SPACER-FAUCET  
137079-02-CHT

BRACKET-SUPPORT  
142093-01-CHT

FILL INLET  
125697-05-000

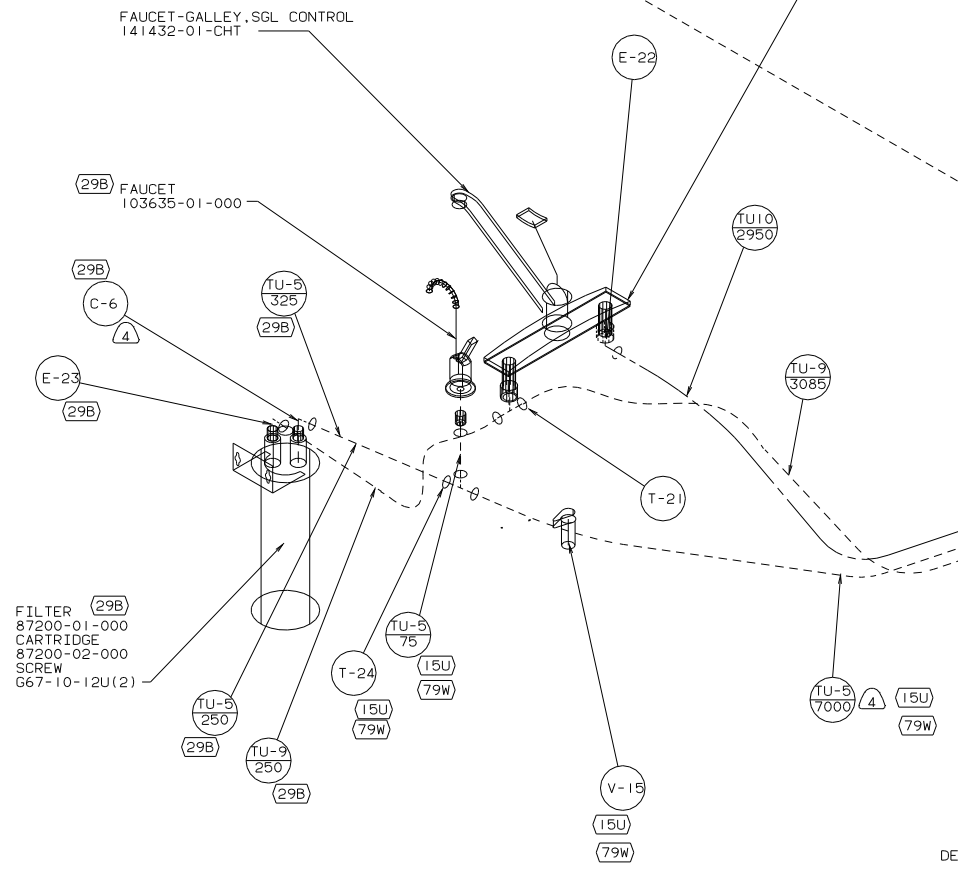

DETAIL B

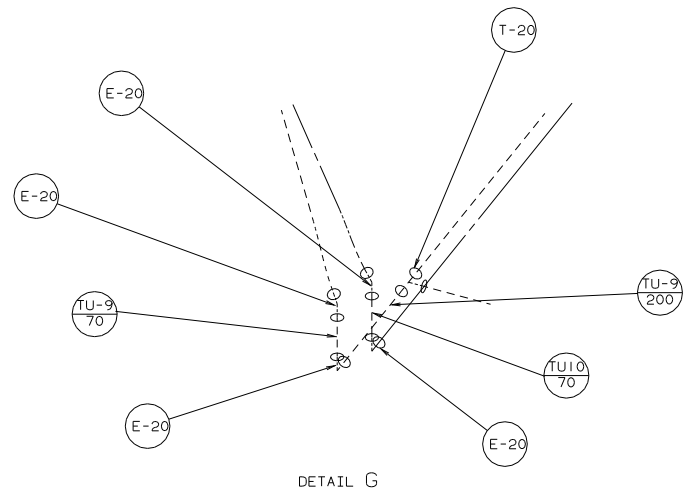

DETAIL G

03 P36L

TITLE: WATER SYSTEM INSTL	
DO NOT SCALE DRAWING	SIZE DWG NO 141645
SHEET 2 OF 4	DATE 07/12/02

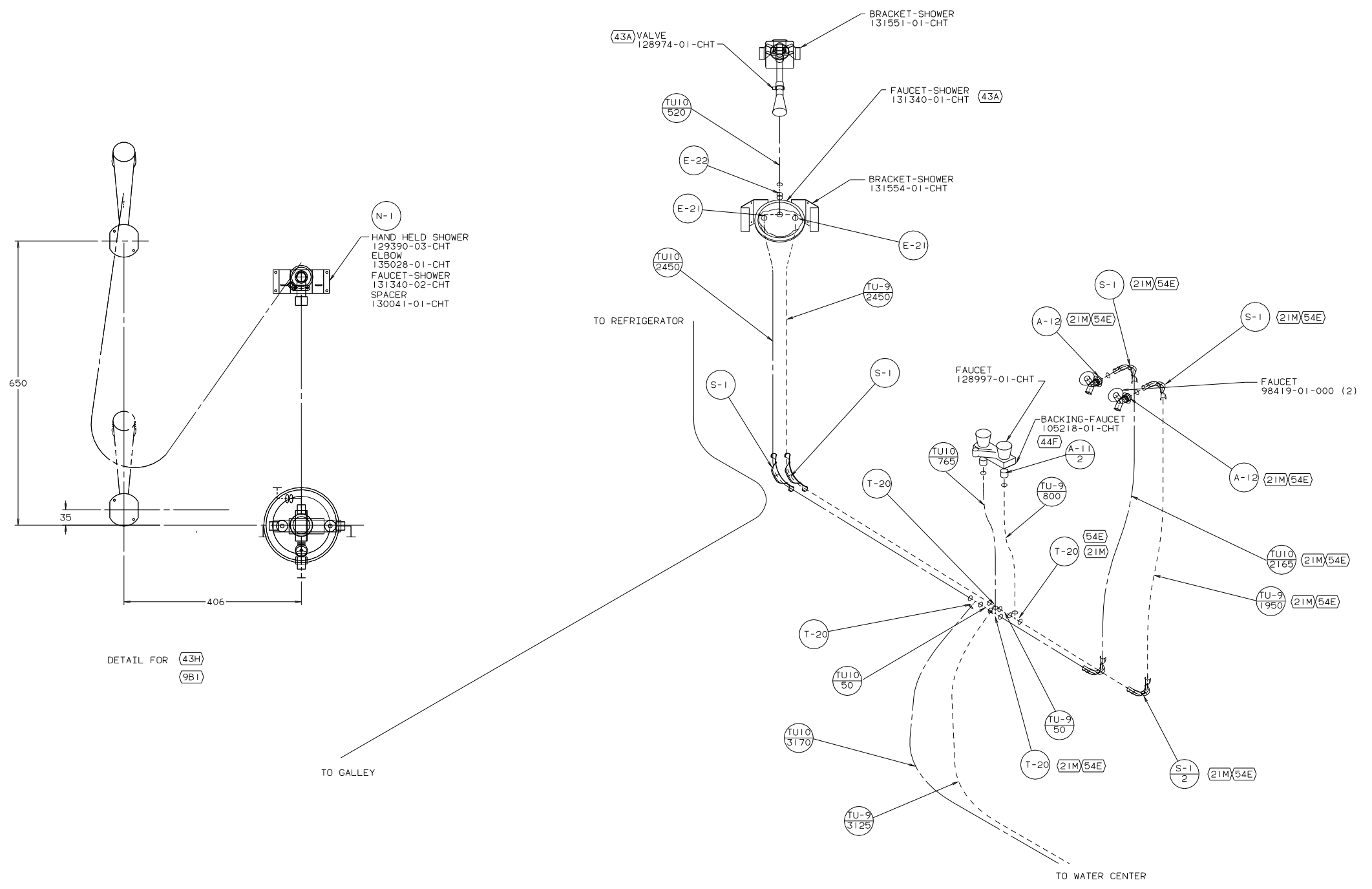

TITLE: 03 P36L		WATER SYSTEM INSTL	
DO NOT SCALE DRAWING	SIZE	DWG NO	141645
SHEET 3 OF 4	I.E.		

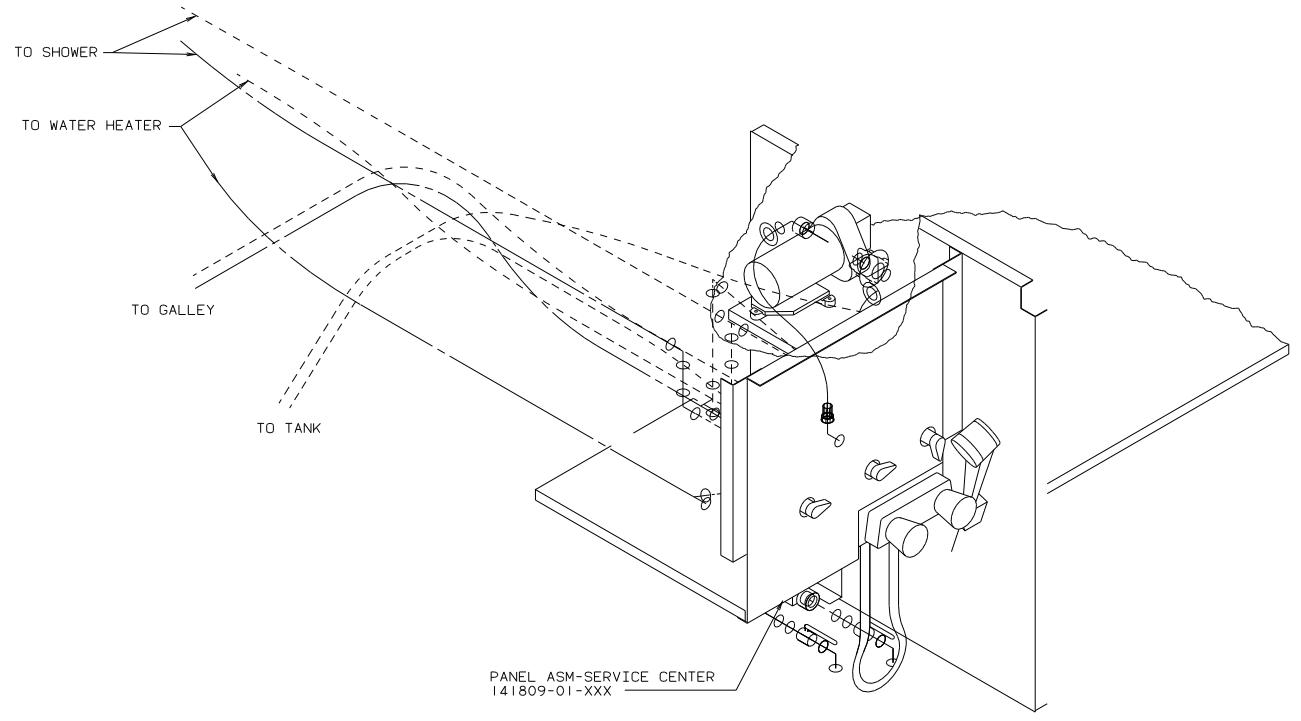

DETAIL DB

03 P36L

TITLE: WATER SYSTEM INSTL		DWG NO 141645	
DO NOT SCALE DRAWING	SIZE	DATE	07/12/02
SHEET 4 OF 4	1E		