



DANGER

Danger of electrical shock, burns or death. Always remove all power sources before attempting any repair, service or diagnostic work. Power can be present from shore power, generator, inverter or battery. All power sources must be disabled and secured before performing any service.



CAUTION

If you lack the skills, tools or equipment to perform diagnostic or repair work leave such work to an authorized Winnebago Industries dealer or other qualified shop.

DWG NO	SHEET	DESCRIPTION
I33004-01	1	W/O SOLAR PANEL LIGHT
I33004-02	2	WITH SOLAR PANEL LIGHT
I33004-03	3	WITH SOLAR PANEL LIGHT

RELEASE	REV A	DATE	DPTR	ADM	DWG NO	133004
REV ZONE	REVISION RECORD		DATE	DTR-ORIG		

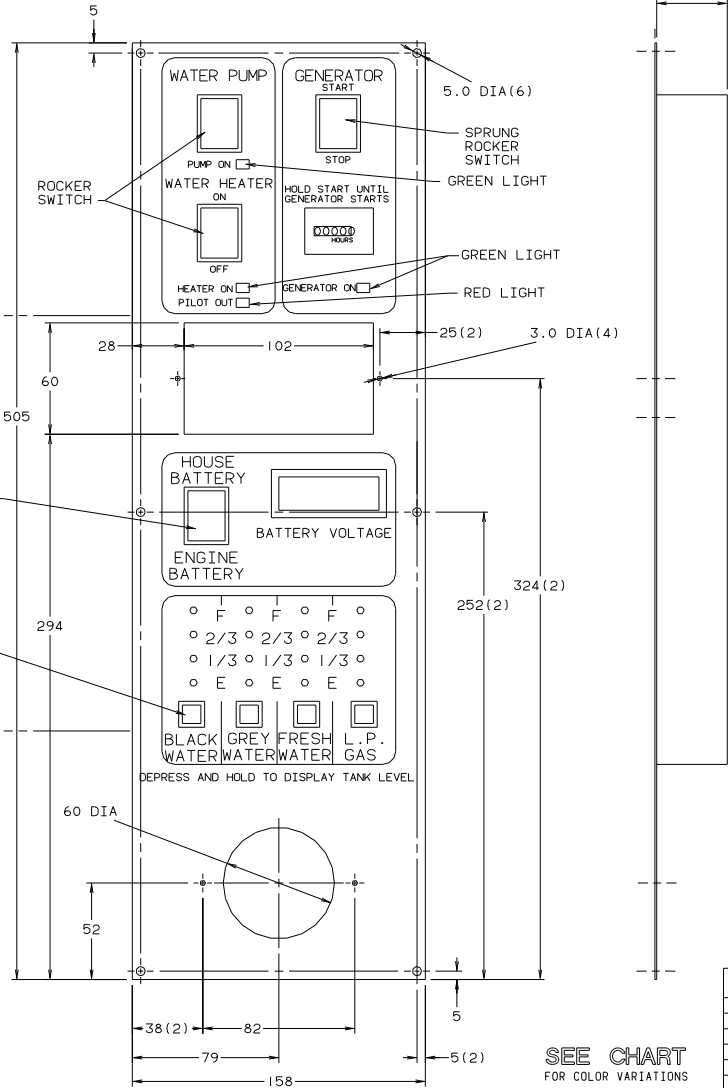
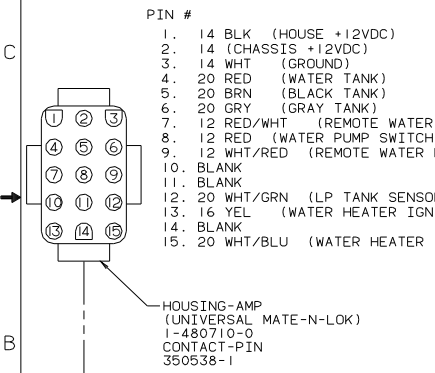
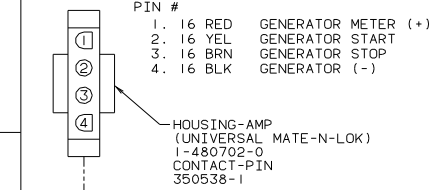

- NOTES:
- SUGGESTED VENDOR: VENTLINE.
 - BLACK PANEL WITH WHITE GRAPHICS.
 - LETTERS ON MAIN HEADING TO BE 5MM HIGH.
 - CUTOUT FOR PANEL TO BE 135 X 350 MIN/ 140 X 380 MAX.
 - SWITCH RATING SHALL BE EMBOSSED ON THE SIDE OF THE 12V SWITCHES.

SEE CHART
FOR COLOR VARIATIONS
OF THIS PART

DTR		DATE	UNSPECIFIED TOLERANCES ARE:	MATERIAL:
CHR		DATE	WHOLE DIM (XX)	+
P E		DATE	ONE-PLACE (X.XX)	+
M E		DATE	TWO-PLACE (X.XXX)	+
DNR		DATE	ANGLE	+
		DATE	THIRD ANGLE PROJECTION	+
LAYOUT NO	TITLE:		PANEL-MONITOR	
DIA #	SCALE: 0:1	DO NOT SCALE DRAWING	SHEET 1 OF 3	DWG NO 133004
ALL DIMENSIONS ARE IN MILLIMETERS				

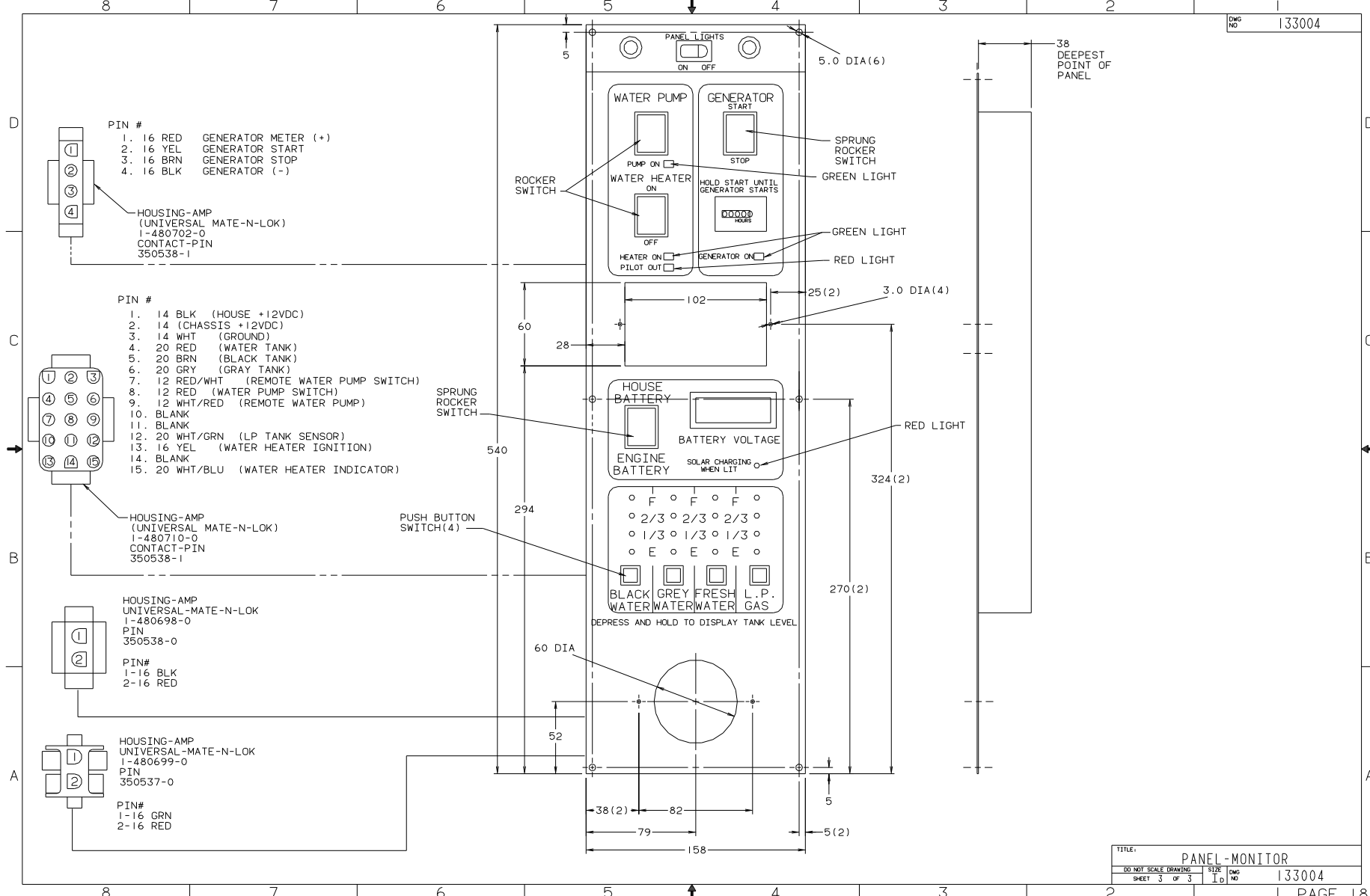

- PIN #
- 1. 16 RED GENERATOR METER (+)
 - 2. 16 YEL GENERATOR START
 - 3. 16 BRN GENERATOR STOP
 - 4. 16 BLK GENERATOR (-)

HOUSING-AMP
(UNIVERSAL MATE-N-LOK)
1-480702-0
CONTACT-PIN
350538-1

- PIN #
- 1. 14 BLK (HOUSE +12VDC)
 - 2. 14 (CHASSIS +12VDC)
 - 3. 14 WHT (GROUND)
 - 4. 20 RED (WATER TANK)
 - 5. 20 BRN (BLACK TANK)
 - 6. 20 GRY (GRAY TANK)
 - 7. 12 RED/WHT (REMOTE WATER PUMP SWITCH)
 - 8. 12 RED (WATER PUMP SWITCH)
 - 9. 12 WHT/RED (REMOTE WATER PUMP)
 - 10. BLANK
 - 11. BLANK
 - 12. 20 WHT/GRN (LP TANK SENSOR)
 - 13. 16 YEL (WATER HEATER IGNITION)
 - 14. BLANK
 - 15. 20 WHT/BLU (WATER HEATER INDICATOR)

HOUSING-AMP
(UNIVERSAL MATE-N-LOK)
1-480710-0
CONTACT-PIN
350538-1

HOUSING-AMP
UNIVERSAL-MATE-N-LOK
1-480698-0
PIN
350538-0

PIN#
1-16 BLK
2-16 RED

HOUSING-AMP
UNIVERSAL-MATE-N-LOK
1-480699-0
PIN
350537-0

PIN#
1-16 GRN
2-16 RED

TITLE		PANEL-MONITOR	
DO NOT SCALE DRAWING	SHEET 3 OF 3	SIZE I D	DWG NO 133004