



DANGER

Danger of electrical shock, burns or death. Always remove all power sources before attempting any repair, service or diagnostic work. Power can be present from shore power, generator, inverter or battery. All power sources must be disabled and secured before performing any service.



CAUTION

If you lack the skills, tools or equipment to perform diagnostic or repair work leave such work to an authorized Winnebago Industries dealer or other qualified shop.

WITH HEAT PUMP

VENDOR SUPPLIED HARNESS

ORG WIRE IS REMOVED FROM TERMINAL AND CONNECTED TO ORG/BLK WIRE THEN WHT/BLK WIRE IS CONNECTED TO THE TERMINAL WHERE TH ORG WIRE WAS.

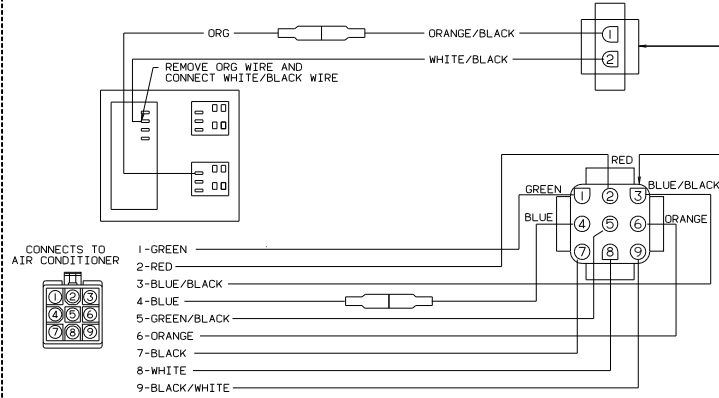

WINNEBAGO SUPPLIED HARNESS

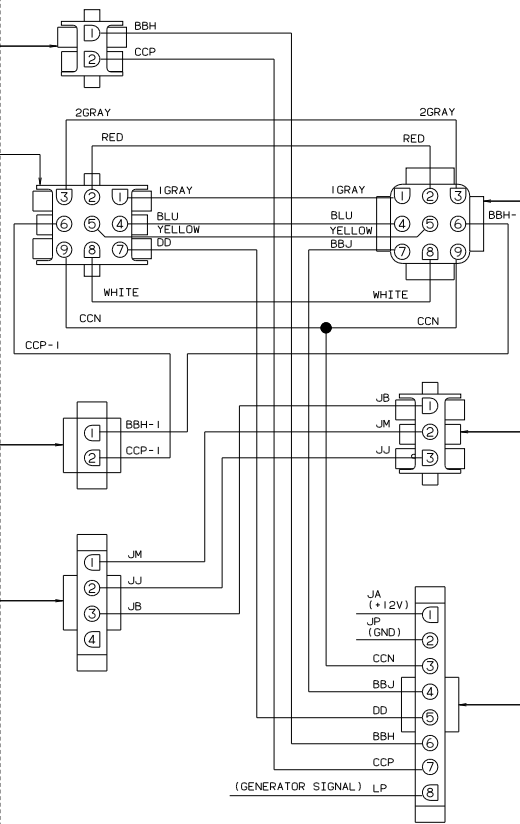

THERMOSTAT

- 1-GRY (FREEZE SWITCH & EXCLUSION RELAY)
- 2-RED (+12VDC)
- 3-GRY (FREEZE SWITCH & EXCLUSION RELAY)
- 4-BLU (-12VDC)
- 5-YEL (COOLING COMPRESSOR #1)
- 6-ORG (COOLING COMPRESSOR #2)
- 7-BLK (FAN HIGH)
- 8-WHT (HEAT PUMP)
- 9-PUR (FAN LOW)

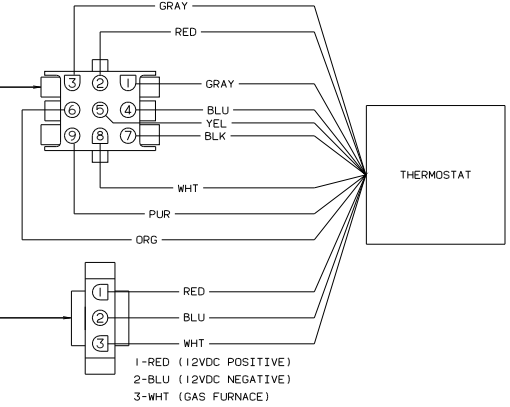

FURNACE

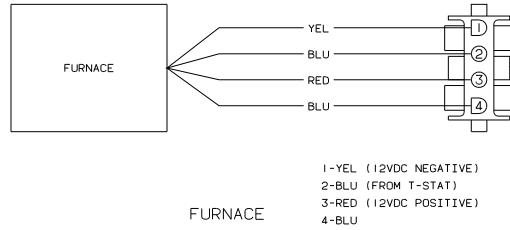

LOAD SHEDDER BOARD

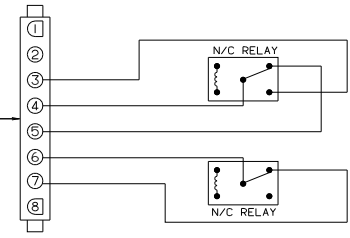

WIRING DIAGRAM-THERMOSTAT, EXT
(WIRE ASM 138131)
(WITH HEAT PUMP)

NOTES: 1 RLC FOR 2001 THIS RESET WAS DELETED.