



DANGER

Danger of electrical shock, burns or death. Always remove all power sources before attempting any repair, service or diagnostic work. Power can be present from shore power, generator, inverter or battery. All power sources must be disabled and secured before performing any service.



CAUTION

If you lack the skills, tools or equipment to perform diagnostic or repair work leave such work to an authorized Winnebago Industries dealer or other qualified shop.

D
C
B
A

0 POSITIVE POST ON CHASSIS BATTERY (VW)
 TO STARTER RELAY CHASSIS BATTERY SIDE (FORD C-BODY)
 TO POWER BUSS BAR ON FIREWALL (CHEVY C-BODY)
 TO CHASSIS SIDE OF BATTERY MODE SOLENOID (CHEVY, FORD, OSHKOSH, F. G. & M-SERIES)
 TO AUTO FUSE BLOCK (CHEVY D-SERIES)

TO NEGATIVE POST ON CHASSIS BATTERY (VW)
 TO GROUND STUD (FORD & CHEVY C-BODY)
 TO GROUND STUD (CHEVY, FORD, OSHKOSH, D. F. G. & M-SERIES)

TO CHASSIS IGNITION FEED CIRCUIT (BLK/BLUE WIRE VW)
 TO RUN ONLY CIRCUIT (PUR/ORN WIRE FORD C-BODY)
 TO AUTO FUSE BLOCK IGNITION CIRCUIT (CHEVY C-BODY)
 TO AUTO FUSE BLOCK IGNITION CIRCUIT (CHEVY, FORD, OSHKOSH, D. F. G. & M-SERIES)

SPLICES INTO LEFT HEADLAMP WIRING COLOR-(WHT/BLK WIRE VW)
 SPLICES INTO LEFT HEADLAMP HIGH BEAM CIRCUIT COLOR-(GRN/BLK WIRE FORD C-BODY)
 SPLICES INTO LEFT HEADLAMP HIGH BEAM CIRCUIT COLOR-(LTGRN WIRE CHEVY C-BODY)
 SPLICES INTO LEFT HEADLAMP HIGH BEAM CIRCUIT ON D, F. G. & M-SERIES
 COLOR-(LTGRN WIRE GM CHASSIS)(CIRCUIT NB 14PUR ON FORD, OSHKOSH & SPARTAN)

SPLICES INTO LEFT HEADLAMP WIRING COLOR-(YEL/BLK WIRE VW)
 SPLICES INTO LEFT HEADLAMP LOW BEAM CIRCUIT COLOR-(RED/BLK WIRE FORD C-BODY)
 SPLICES INTO LEFT HEADLAMP LOW BEAM CIRCUIT COLOR-(TAN WIRE CHEVY C-BODY)
 SPLICES INTO LEFT HEADLAMP LOW BEAM CIRCUIT ON D, F. G. & M-SERIES
 COLOR-(TAN WIRE GM CHASSIS)(CIRCUIT NA 14PUR ON FORD, OSHKOSH & SPARTAN)

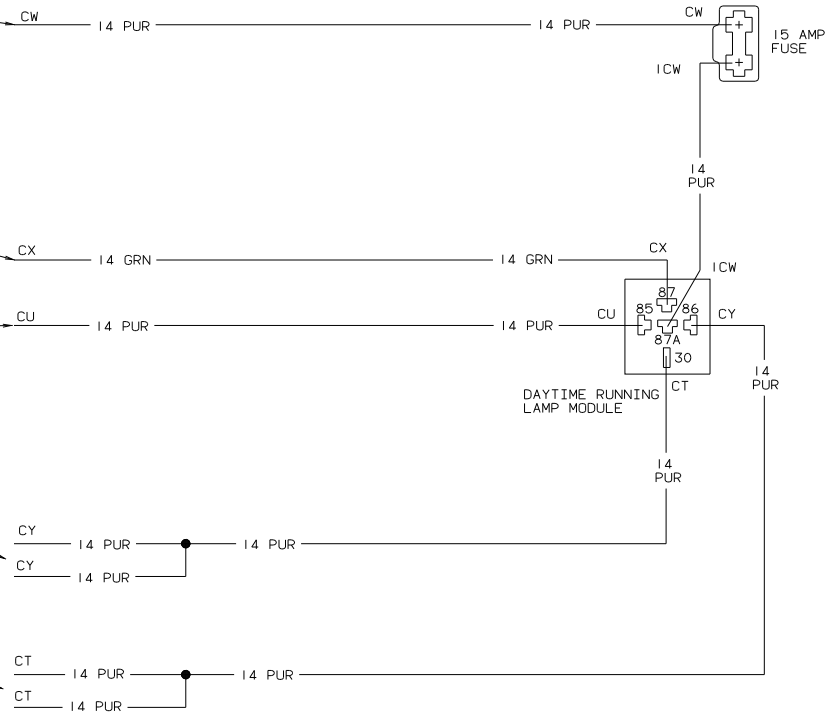

WINNEBAGO 96 MOTORHOMES

DTR	DATE	UNSPECIFIED TOLERANCES ARE:	MATERIAL:
CHR	DATE	WHOLE (DIM XXX)	+
P E	DATE	ONE-PLACE (X.XX)	+
M E	DATE	TWO-PLACE (X.XXX)	+
DNR	DATE	ANGLE	+
	DATE	THIRD ANGLE PROJECTION	⊕ ←

LAYOUT NO. TITLE: WIRING DIAGRAM-DAY RUN LAMPS
 DIA # SCALE: NONE DO NOT SCALE DRAWING SHEET 1 OF 1 SIZE DWG NO 121694