

DETAIL A

DETAIL B

DETAIL C

DETAIL D

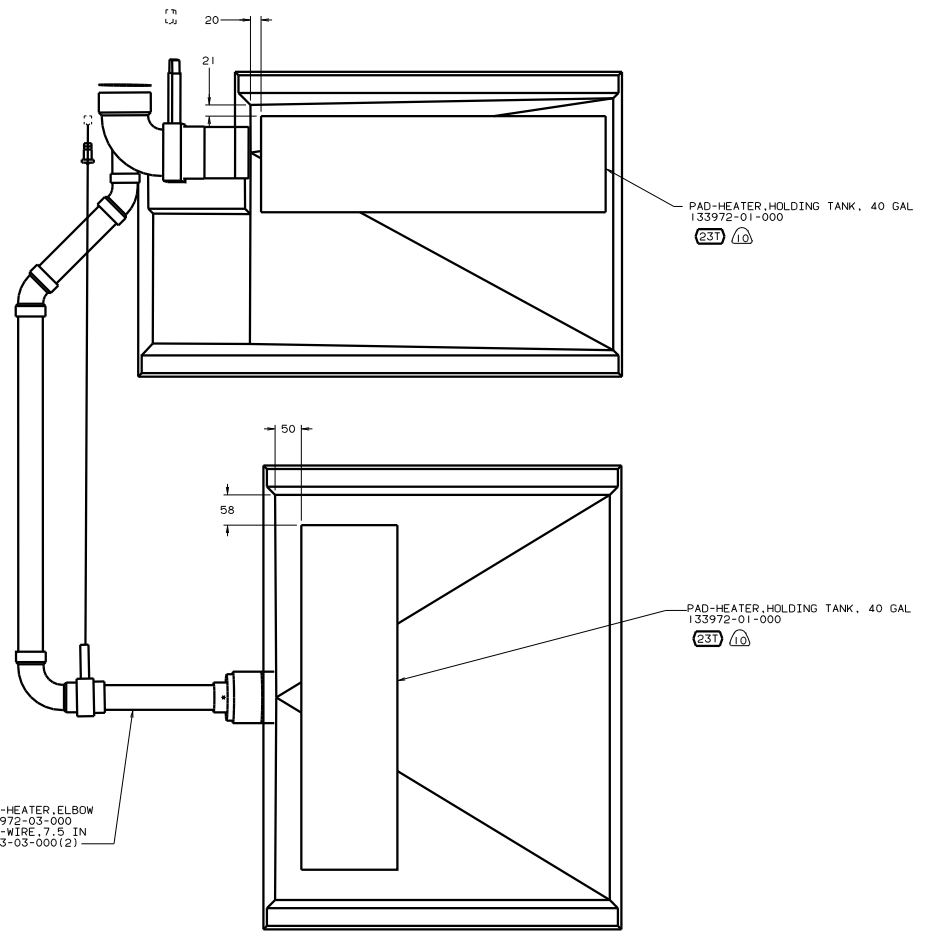

VIEW E-E

