

DETAIL A

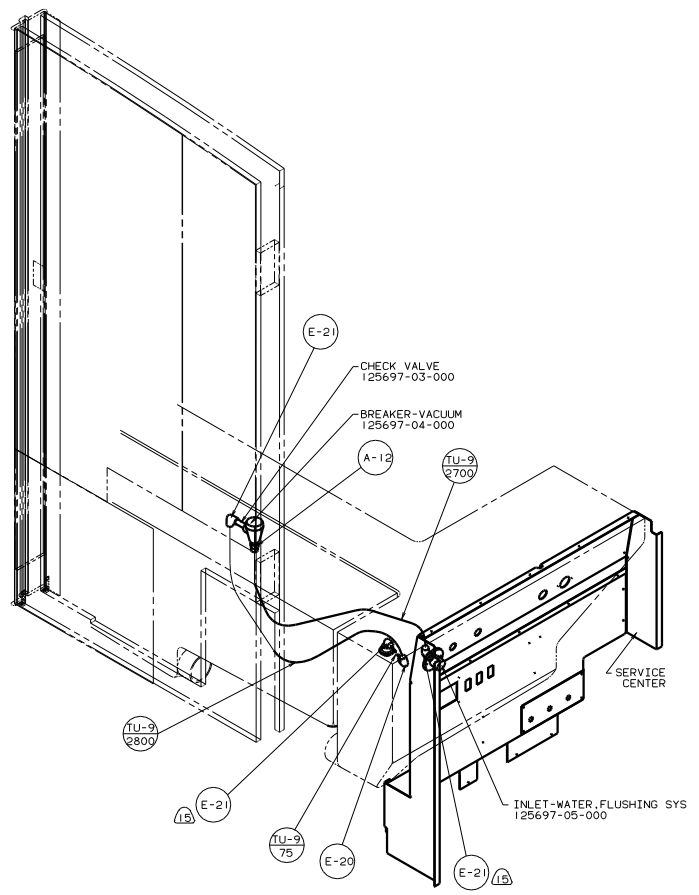

DETAIL B
FLUSHING SYSTEM

99 Q40J/JD

TITLE		WATER SYSTEM INSTL	
NO	SCALE	REV	DATE
2		1	
SHEET 2 OF 7		129971	

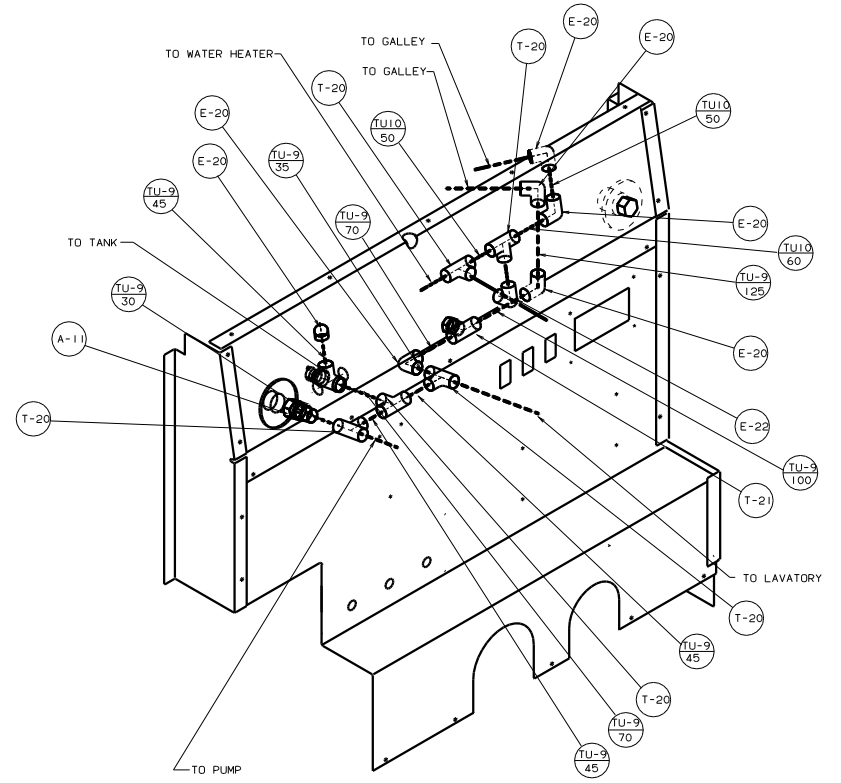
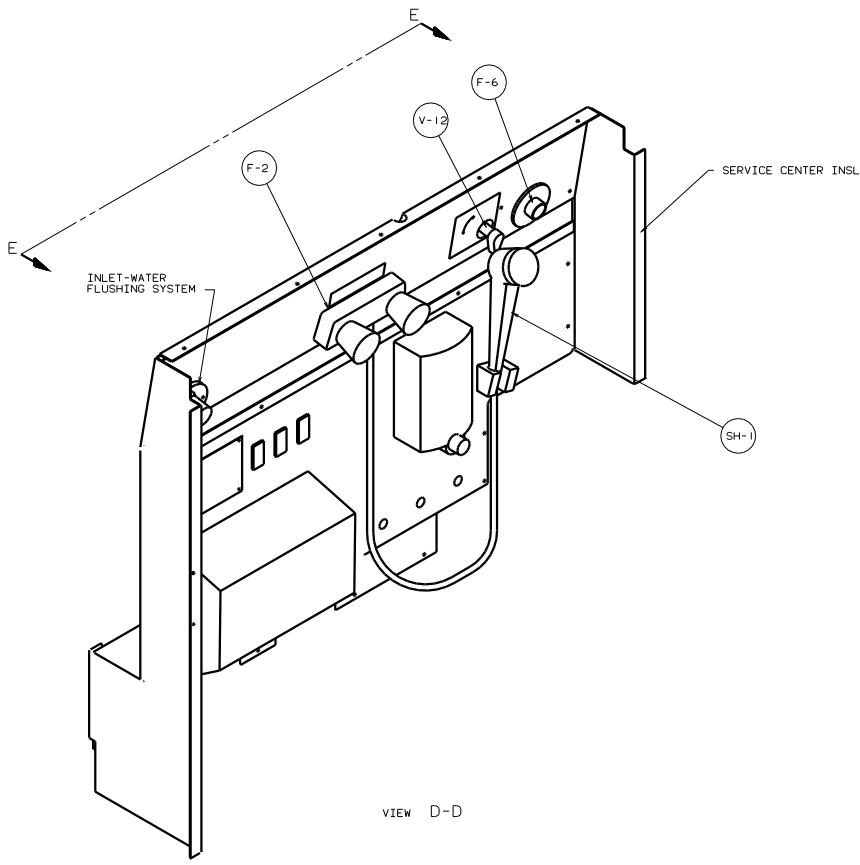

99 Q40J/JD	
TITLE: WATER SYSTEM INSL	
NO. OF SHEETS	TOT. SHEETS
4 OF 7	16
DWG. NO. 129971	

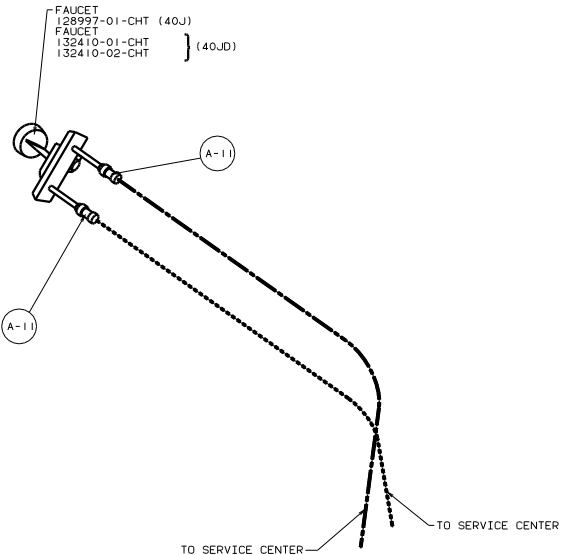

DETAIL H

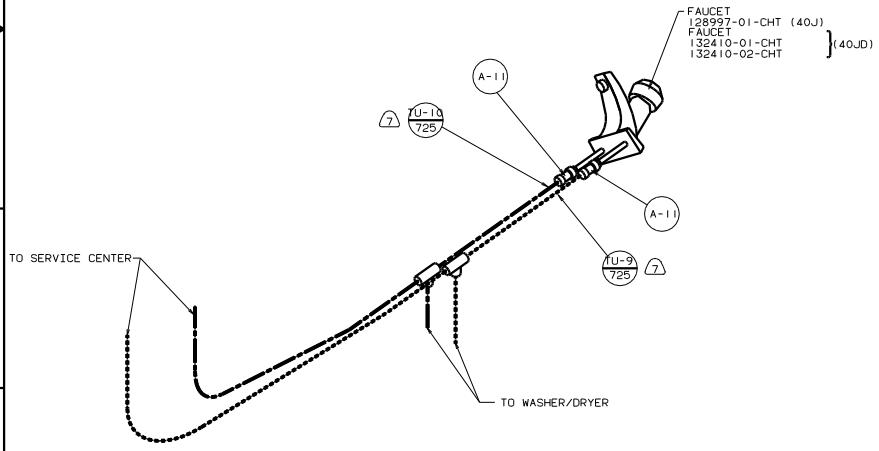

DETAIL J

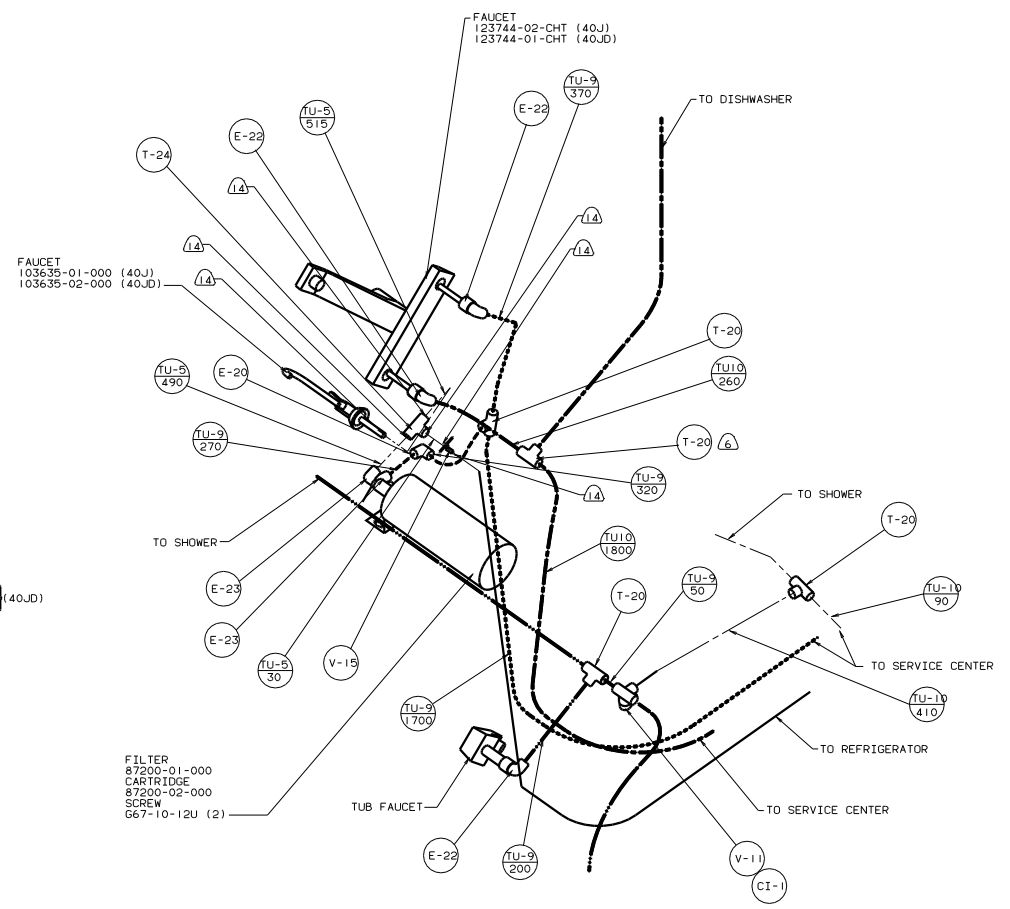

DETAIL K