

- SINK 110654-01-000 (US/CAN)
- RETAINER 77351-24-000 (2)
- 77351-30-000
- 83125-07-000
- 77351-32-000
- STRAINER W/BASKET 92303-01-000 (2)
- SEALER 91255-02-000 (A/R)
- WASHER 127440-02-CHT (2)
- SCREW G67-06-10U (22)

FRONT OF VEHICLE

- (16) 038K.
- (18) 038KD.
- (14) DISHWASHER WITHOUT 215.
- (13) 21N DISHWASHER.
- (12) INCLUDED WITH GALLEY STRAINER.
- (11) SECURE DRAIN TUBES TO FLOOR.
- (10) 54E WASHER/DRYER.
- (9) NOT USED ON CANADIAN UNITS.
- (8) VENT PIPE MUST PROJECT 51 MIN TO 64 MAX ABOVE ROOF FOR PROPER FIT AND FUNCTION.
- (7) SEE DWG 61607-01-000 FOR INSTL OF GROMMET.
- (6) SEAL ALL AROUND SHOWER PAN WITH SILICONE 78474-01-CHT.

5. FOR CANADIAN UNITS EACH HOLDING TANK SHALL HAVE A CSA APPROVAL STAMPED NEAR THE IAPMO APPROVAL.
4. ALL EXTERIOR OPENINGS AROUND PIPE TO BE SEALED WITH 69637-01-000.
3. ALL PIPE AND FITTINGS TO BE ASSEMBLED WITH SOLVENT 4020-01-000.
2. SLOPE OF TRAP MUST BE 6 PER 300 MINIMUM.
1. SLOPE OF HORIZONTAL PIPING TO BE 6 PER 300 MINIMUM.

17. SECURE PIPES TO CABINET USING WIRE TIE 108046-02-000 AND SCREW G67-10-12U (8).

- (54V) FLOOR COVERING/BATH-VINYL
- (54U) FLOOR/BATH-CERAMIC TILE

WINNEBAGO		99 038KD
QTY	DATE	UNSPECIFIED TOLERANCES ARE:
CHG	DATE	WHOLE DIM (IN)
D/E	DATE	ONE-PLACE (IN.XI)
D/E	DATE	TWO-PLACE (IN.XXX)
DATE	DATE	THREE-PLACE (IN.XXXX)
DATE	DATE	FOUR-PLACE (IN.XXXX)
DATE	DATE	FIVE-PLACE (IN.XXXXX)
DATE	DATE	SIX-PLACE (IN.XXXXX)
DATE	DATE	SEVEN-PLACE (IN.XXXXX)
DATE	DATE	EIGHT-PLACE (IN.XXXXX)
DATE	DATE	NINE-PLACE (IN.XXXXX)
DATE	DATE	TEN-PLACE (IN.XXXXX)
DATE	DATE	ELEVEN-PLACE (IN.XXXXX)
DATE	DATE	TWELVE-PLACE (IN.XXXXX)
DATE	DATE	THIRTEEN-PLACE (IN.XXXXX)
DATE	DATE	FOURTEEN-PLACE (IN.XXXXX)
DATE	DATE	FIFTEEN-PLACE (IN.XXXXX)
DATE	DATE	SIXTEEN-PLACE (IN.XXXXX)
DATE	DATE	SEVENTEEN-PLACE (IN.XXXXX)
DATE	DATE	EIGHTEEN-PLACE (IN.XXXXX)
DATE	DATE	NINETEEN-PLACE (IN.XXXXX)
DATE	DATE	TWENTY-PLACE (IN.XXXXX)
DATE	DATE	TWENTY-ONE PLACE (IN.XXXXX)
DATE	DATE	TWENTY-TWO PLACE (IN.XXXXX)
DATE	DATE	TWENTY-THREE PLACE (IN.XXXXX)
DATE	DATE	TWENTY-FOUR PLACE (IN.XXXXX)
DATE	DATE	TWENTY-FIVE PLACE (IN.XXXXX)
DATE	DATE	TWENTY-SIX PLACE (IN.XXXXX)
DATE	DATE	TWENTY-SEVEN PLACE (IN.XXXXX)
DATE	DATE	TWENTY-EIGHT PLACE (IN.XXXXX)
DATE	DATE	TWENTY-NINE PLACE (IN.XXXXX)
DATE	DATE	THIRTY PLACE (IN.XXXXX)
DATE	DATE	THIRTY-ONE PLACE (IN.XXXXX)
DATE	DATE	THIRTY-TWO PLACE (IN.XXXXX)
DATE	DATE	THIRTY-THREE PLACE (IN.XXXXX)
DATE	DATE	THIRTY-FOUR PLACE (IN.XXXXX)
DATE	DATE	THIRTY-FIVE PLACE (IN.XXXXX)
DATE	DATE	THIRTY-SIX PLACE (IN.XXXXX)
DATE	DATE	THIRTY-SEVEN PLACE (IN.XXXXX)
DATE	DATE	THIRTY-EIGHT PLACE (IN.XXXXX)
DATE	DATE	THIRTY-NINE PLACE (IN.XXXXX)
DATE	DATE	FOURTY PLACE (IN.XXXXX)
DATE	DATE	FOURTY-ONE PLACE (IN.XXXXX)
DATE	DATE	FOURTY-TWO PLACE (IN.XXXXX)
DATE	DATE	FOURTY-THREE PLACE (IN.XXXXX)
DATE	DATE	FOURTY-FOUR PLACE (IN.XXXXX)
DATE	DATE	FOURTY-FIVE PLACE (IN.XXXXX)
DATE	DATE	FOURTY-SIX PLACE (IN.XXXXX)
DATE	DATE	FOURTY-SEVEN PLACE (IN.XXXXX)
DATE	DATE	FOURTY-EIGHT PLACE (IN.XXXXX)
DATE	DATE	FOURTY-NINE PLACE (IN.XXXXX)
DATE	DATE	FIFTY PLACE (IN.XXXXX)
DATE	DATE	FIFTY-ONE PLACE (IN.XXXXX)
DATE	DATE	FIFTY-TWO PLACE (IN.XXXXX)
DATE	DATE	FIFTY-THREE PLACE (IN.XXXXX)
DATE	DATE	FIFTY-FOUR PLACE (IN.XXXXX)
DATE	DATE	FIFTY-FIVE PLACE (IN.XXXXX)
DATE	DATE	FIFTY-SIX PLACE (IN.XXXXX)
DATE	DATE	FIFTY-SEVEN PLACE (IN.XXXXX)
DATE	DATE	FIFTY-EIGHT PLACE (IN.XXXXX)
DATE	DATE	FIFTY-NINE PLACE (IN.XXXXX)
DATE	DATE	SIXTY PLACE (IN.XXXXX)
DATE	DATE	SIXTY-ONE PLACE (IN.XXXXX)
DATE	DATE	SIXTY-TWO PLACE (IN.XXXXX)
DATE	DATE	SIXTY-THREE PLACE (IN.XXXXX)
DATE	DATE	SIXTY-FOUR PLACE (IN.XXXXX)
DATE	DATE	SIXTY-FIVE PLACE (IN.XXXXX)
DATE	DATE	SIXTY-SIX PLACE (IN.XXXXX)
DATE	DATE	SIXTY-SEVEN PLACE (IN.XXXXX)
DATE	DATE	SIXTY-EIGHT PLACE (IN.XXXXX)
DATE	DATE	SIXTY-NINE PLACE (IN.XXXXX)
DATE	DATE	SEVENTY PLACE (IN.XXXXX)
DATE	DATE	SEVENTY-ONE PLACE (IN.XXXXX)
DATE	DATE	SEVENTY-TWO PLACE (IN.XXXXX)
DATE	DATE	SEVENTY-THREE PLACE (IN.XXXXX)
DATE	DATE	SEVENTY-FOUR PLACE (IN.XXXXX)
DATE	DATE	SEVENTY-FIVE PLACE (IN.XXXXX)
DATE	DATE	SEVENTY-SIX PLACE (IN.XXXXX)
DATE	DATE	SEVENTY-SEVEN PLACE (IN.XXXXX)
DATE	DATE	SEVENTY-EIGHT PLACE (IN.XXXXX)
DATE	DATE	SEVENTY-NINE PLACE (IN.XXXXX)
DATE	DATE	EIGHTY PLACE (IN.XXXXX)
DATE	DATE	EIGHTY-ONE PLACE (IN.XXXXX)
DATE	DATE	EIGHTY-TWO PLACE (IN.XXXXX)
DATE	DATE	EIGHTY-THREE PLACE (IN.XXXXX)
DATE	DATE	EIGHTY-FOUR PLACE (IN.XXXXX)
DATE	DATE	EIGHTY-FIVE PLACE (IN.XXXXX)
DATE	DATE	EIGHTY-SIX PLACE (IN.XXXXX)
DATE	DATE	EIGHTY-SEVEN PLACE (IN.XXXXX)
DATE	DATE	EIGHTY-EIGHT PLACE (IN.XXXXX)
DATE	DATE	EIGHTY-NINE PLACE (IN.XXXXX)
DATE	DATE	NINETY PLACE (IN.XXXXX)
DATE	DATE	NINETY-ONE PLACE (IN.XXXXX)
DATE	DATE	NINETY-TWO PLACE (IN.XXXXX)
DATE	DATE	NINETY-THREE PLACE (IN.XXXXX)
DATE	DATE	NINETY-FOUR PLACE (IN.XXXXX)
DATE	DATE	NINETY-FIVE PLACE (IN.XXXXX)
DATE	DATE	NINETY-SIX PLACE (IN.XXXXX)
DATE	DATE	NINETY-SEVEN PLACE (IN.XXXXX)
DATE	DATE	NINETY-EIGHT PLACE (IN.XXXXX)
DATE	DATE	NINETY-NINE PLACE (IN.XXXXX)
DATE	DATE	HUNDRED PLACE (IN.XXXXX)

FOR DRAINAGE CALL-OUTS SEE DWG NO. 116229-01-000

- SHOWER INSTL-ENCLOSURE
- 123806-02-XXX
- 127290-01-XXX
- DRAIN
- 120981-01-000(USA)
- STRAINER
- 66729-01-000(CSA)
- NUT-STRAINER
- 130405-01-000
- TAIL-PIPE
- 11069-06-000
- WASHER-RUBBER
- 127440-02-CHT

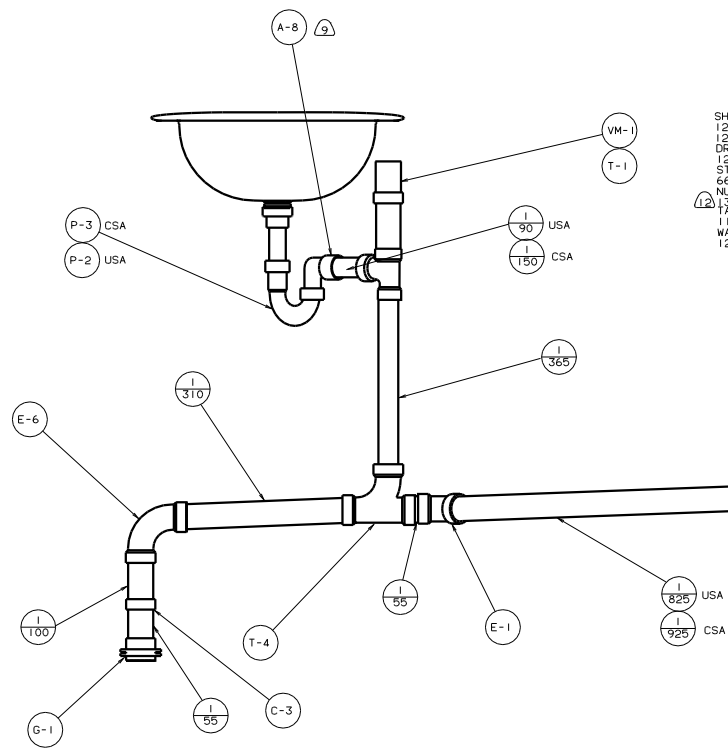

VIEW A-A

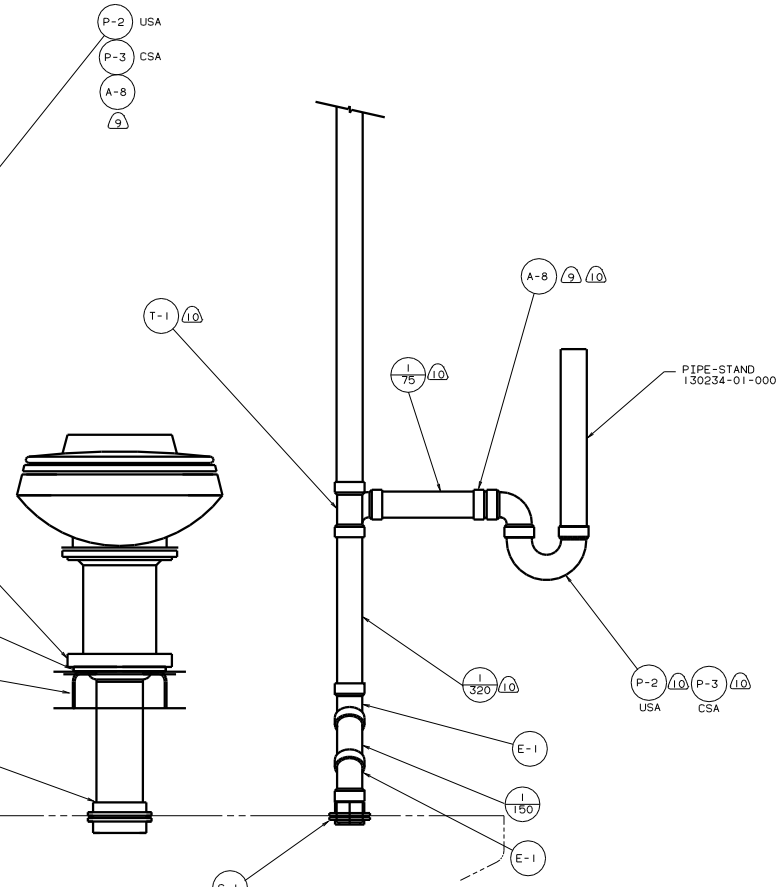

VIEW B-B

- G4U G57-14-72B (8)
- G4V G57-14-64B (8)

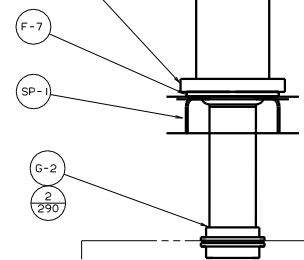

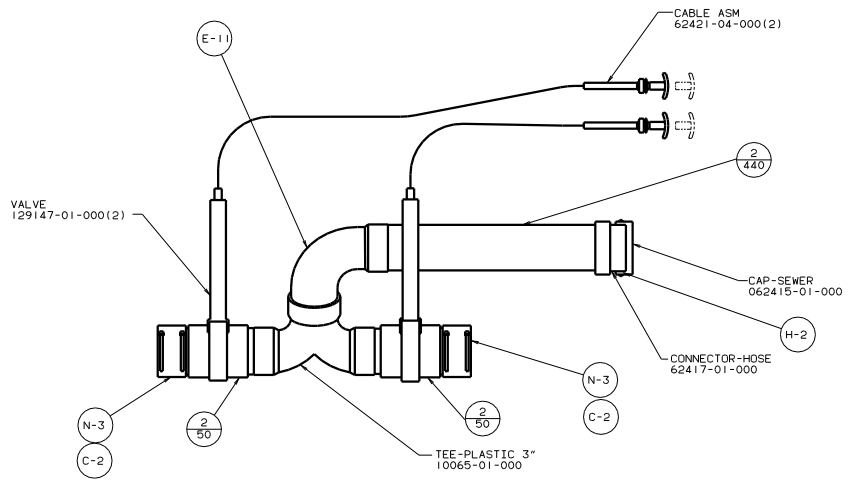

VIEW C-C

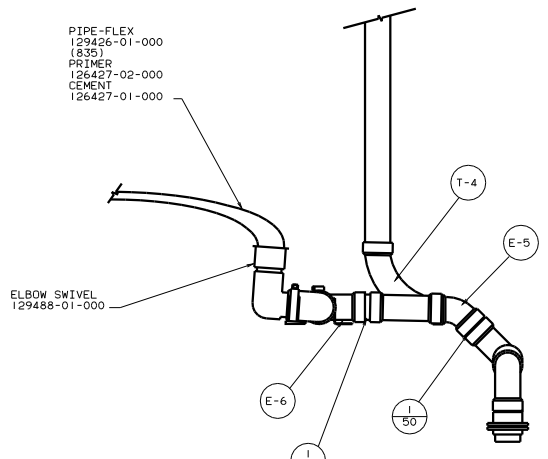

VIEW D-D

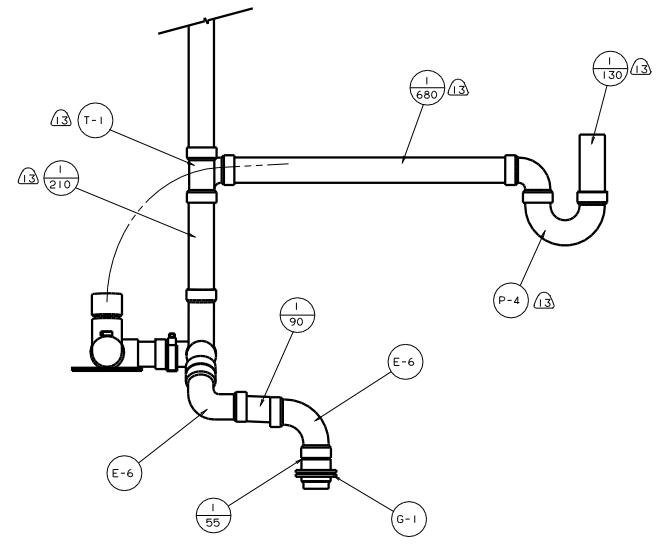



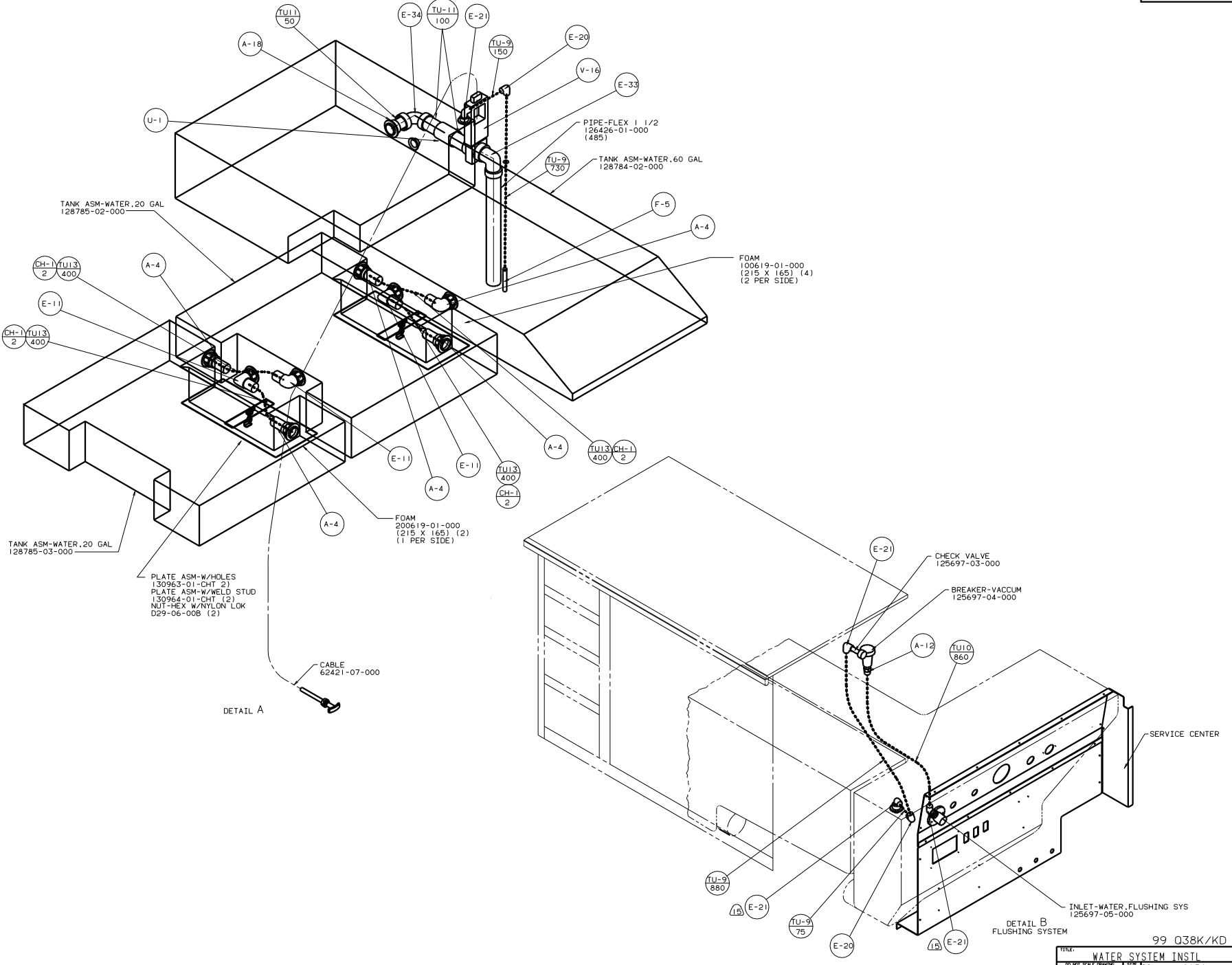

DETAIL A

DETAIL B  
FLUSHING SYSTEM

99 Q38K/KD

TITLE: WATER SYSTEM INSTL	
NO. OF SHEETS	TOTAL SHEETS
SHEET 2 OF 6	16
129591	



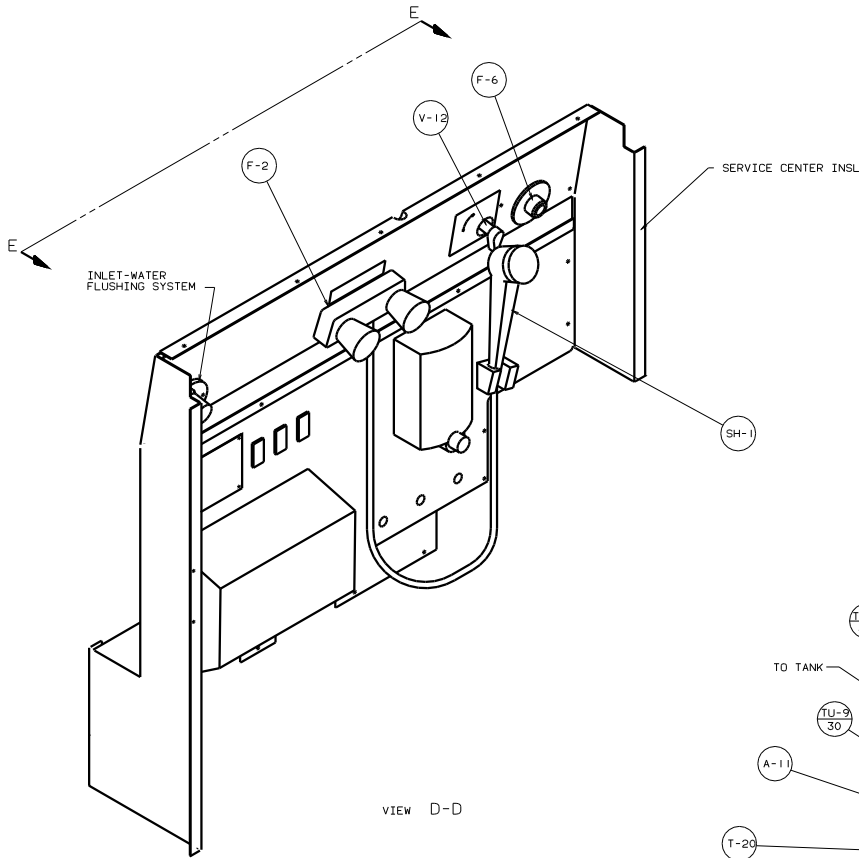

VIEW D-D

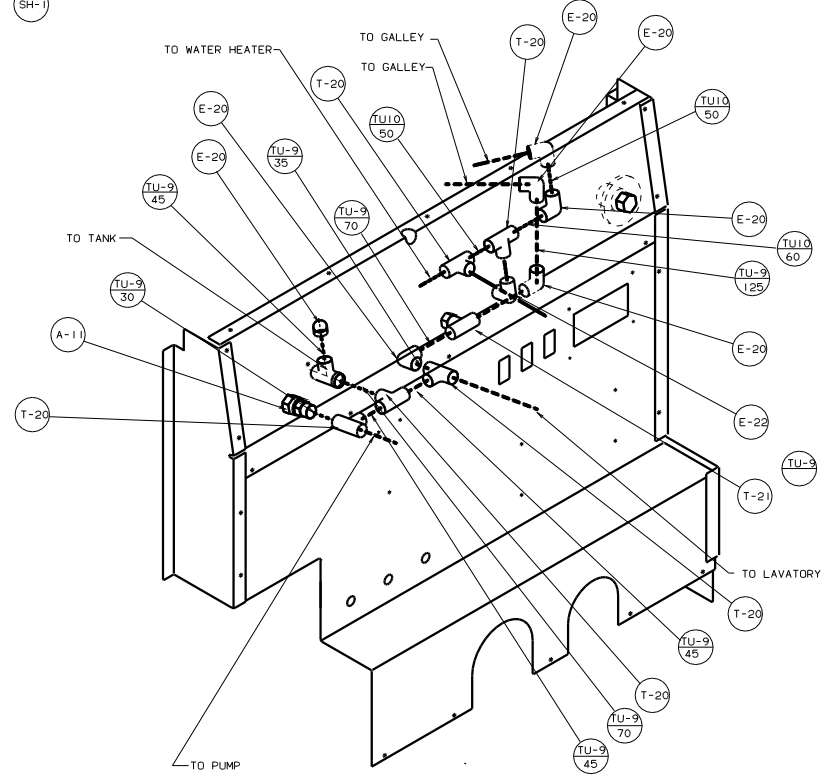

VIEW E-E

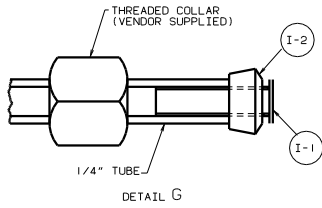
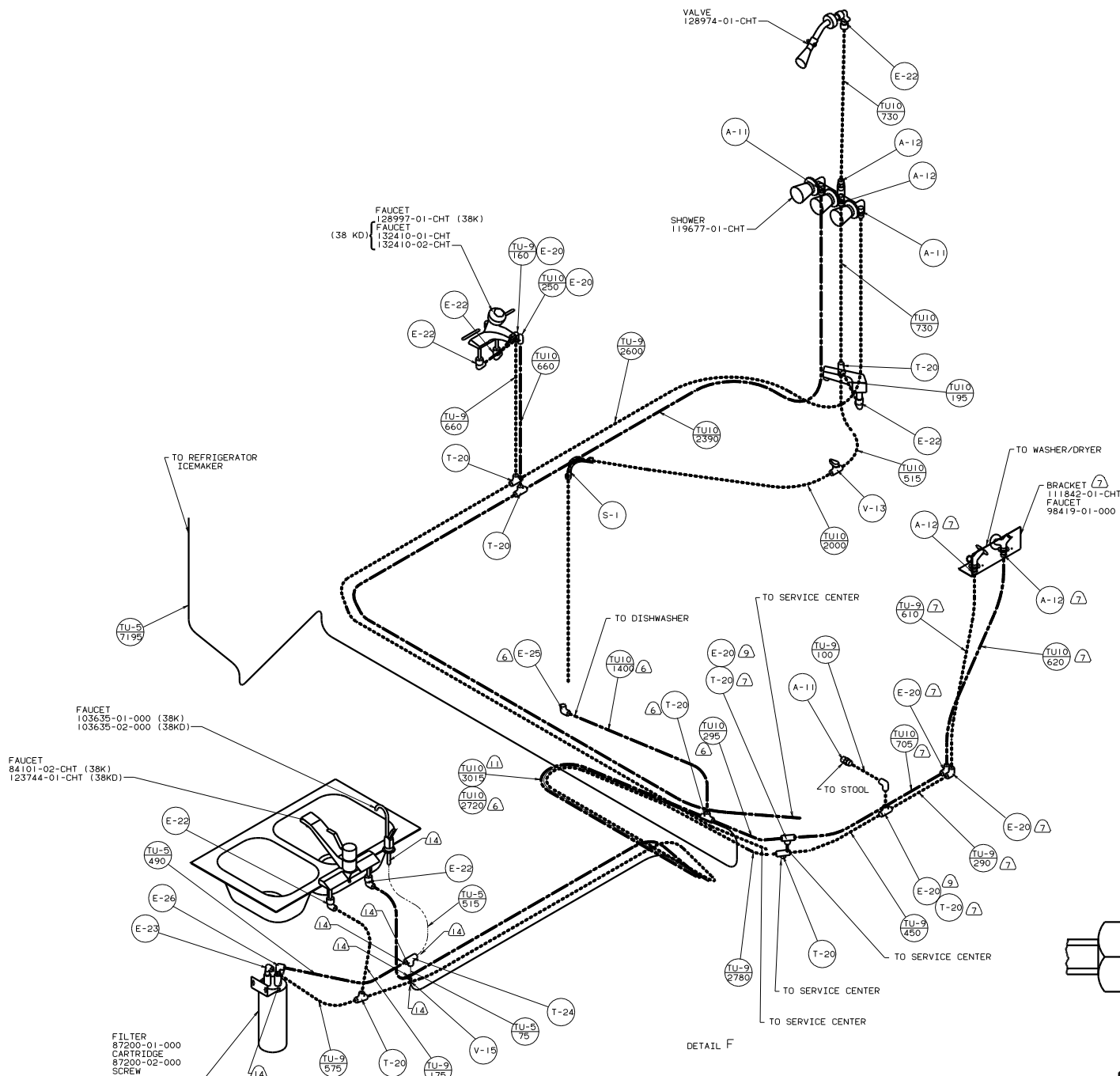

99 Q38K/KD	
TITLE:	WATER SYSTEM INSTL
NO. OF SHEETS:	5 OF 6
SHEET NO.:	5
REV. NO.:	1
DATE:	129591

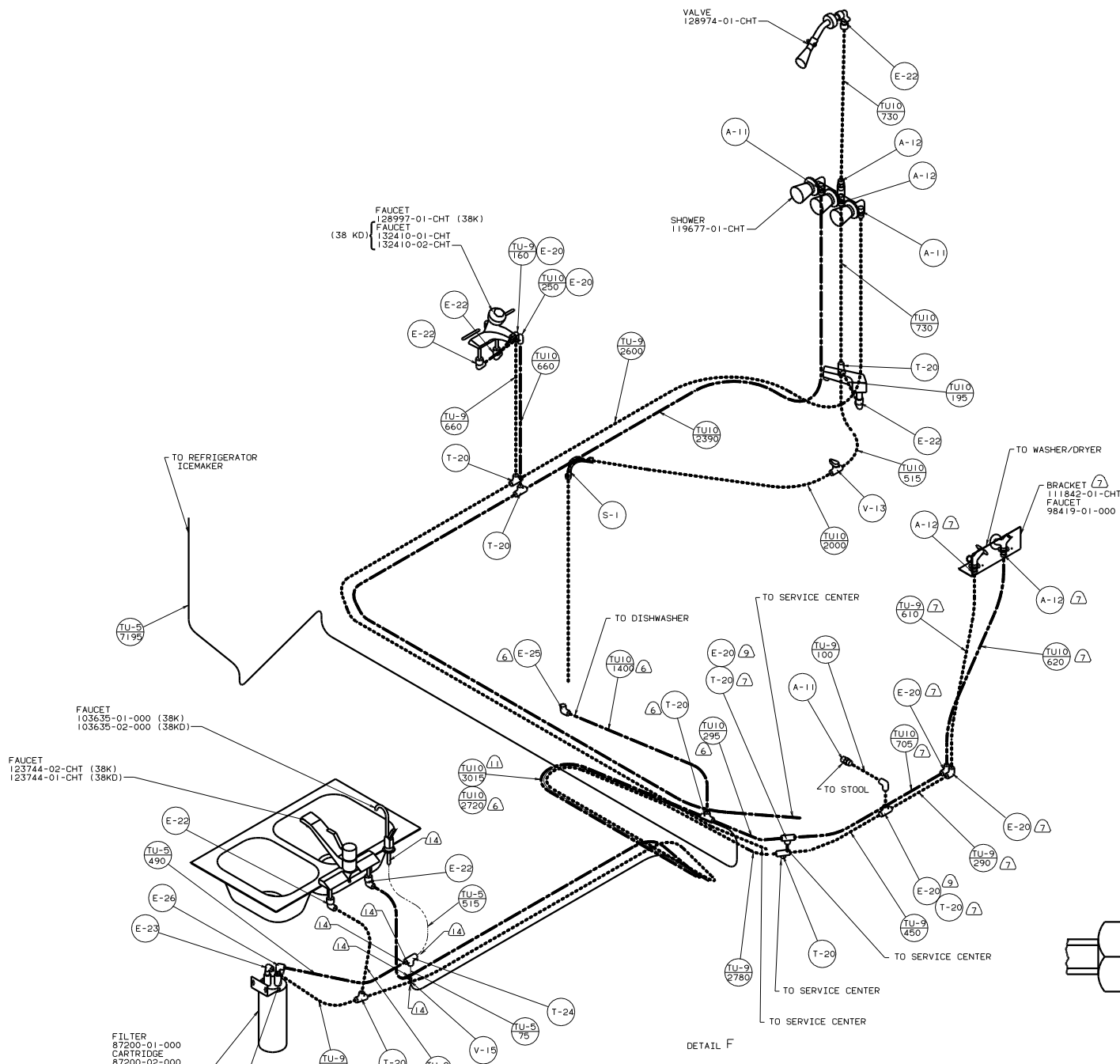

FAUCET  
128997-01-CHT (38K)  
FAUCET  
(38 KD) 132410-01-CHT  
132410-02-CHT

VALVE  
128974-01-CHT

SHOWER  
119677-01-CHT

FAUCET  
103635-01-000 (38K)  
103635-02-000 (38KD)

FAUCET  
123744-02-CHT (38K)  
123744-01-CHT (38KD)

FILTER  
87200-01-000  
CARTRIDGE  
87200-02-000  
SCREW  
G67-10-12U (2)

BRACKET  
111842-01-CHT  
FAUCET  
98419-01-000 (2)

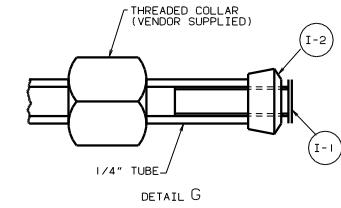

00 Q38K/KD	
TITLE	WATER SYSTEM INSTL
NO. OF SHEETS	5 OF 5
SHEET NO.	5
DATE	129591