

DETAIL D

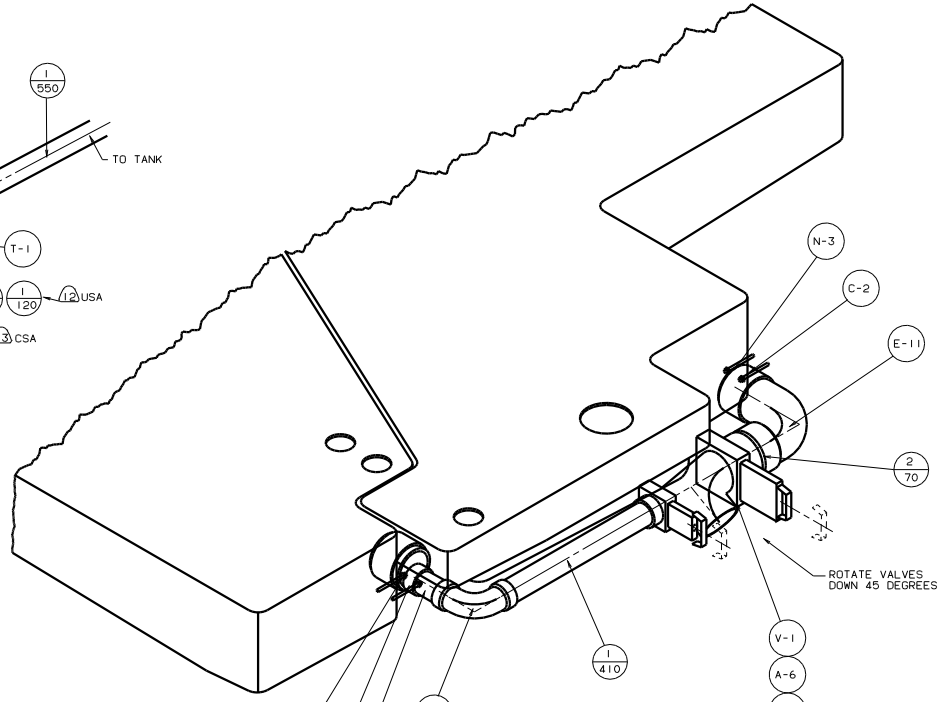

VIEW E-E

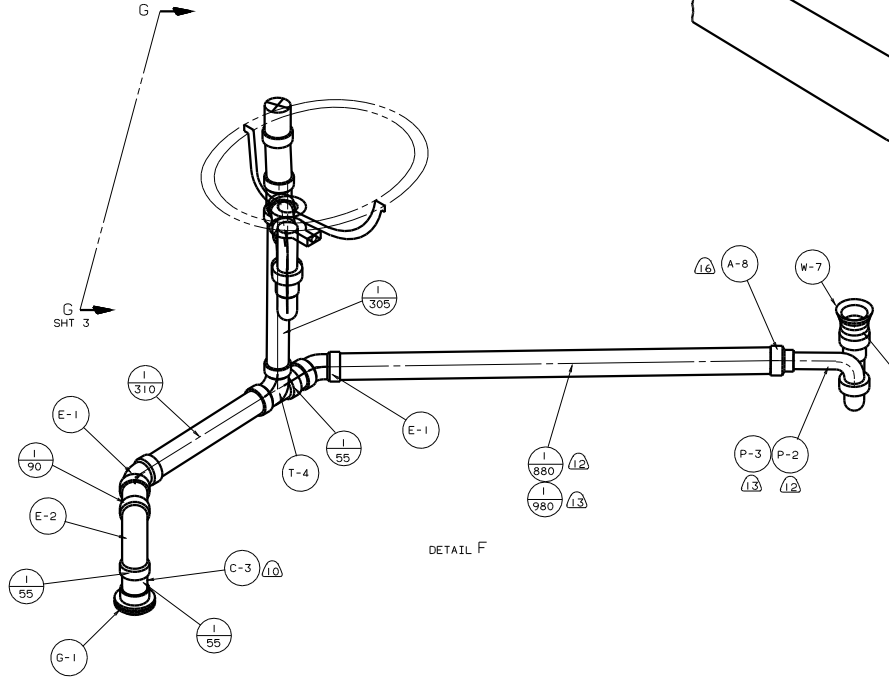

DETAIL F

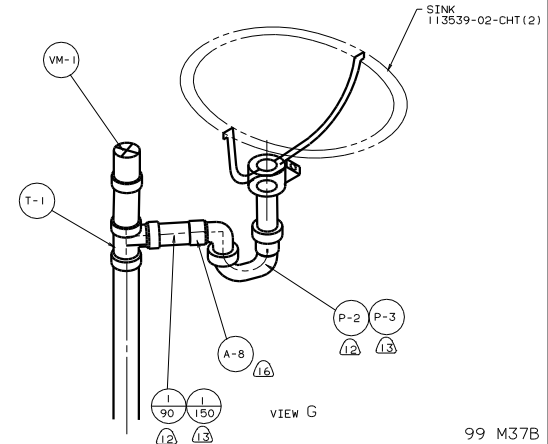

VIEW G

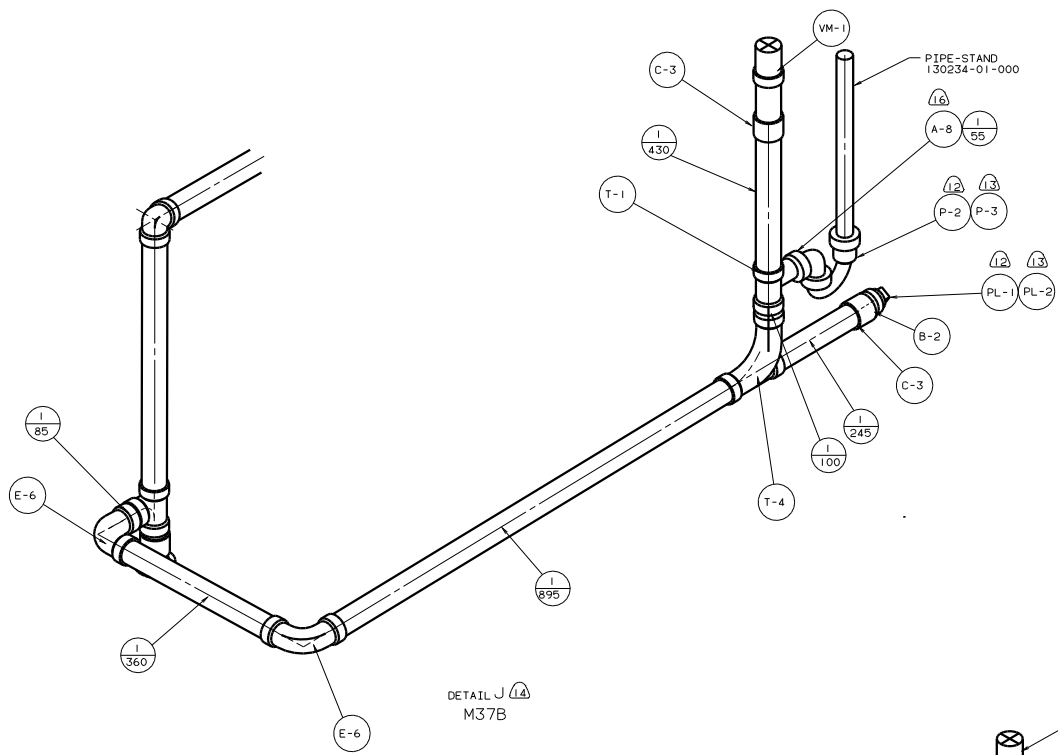

DETAIL J (14)
M37B

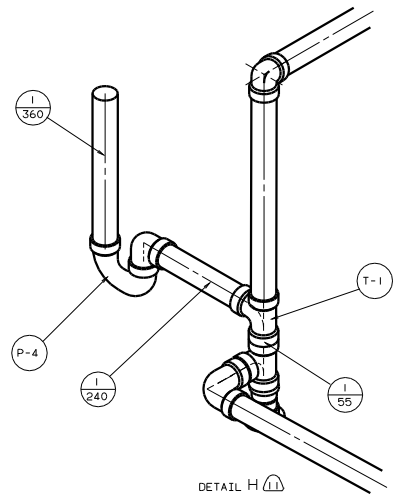

DETAIL H (11)

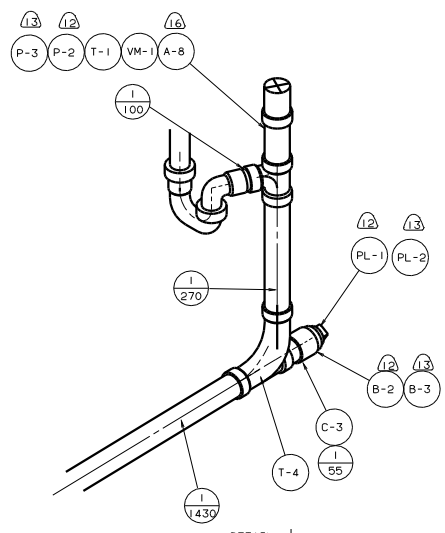

DETAIL J
(LAV. #2)
M39Y

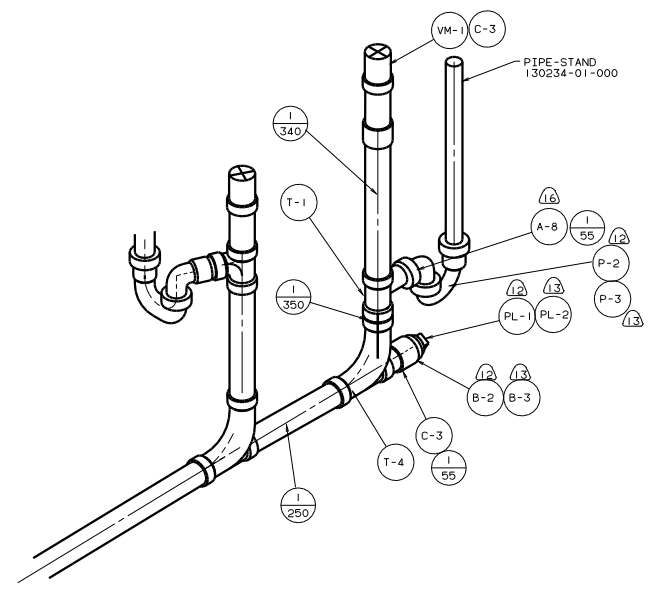

DETAIL J
M39Y

STRAP
126413-02-CHT (2)
SCREW
G39-10-128 (8)

4724
PANEL-CLOSEOUT, WATER HTR
125028-04-CHT
RIVET
113133-01-CHT (2)
47

TANK ASM-HOLDING
128561-02-000

PLATFORM-HOLDING TANK
126714-04-000

PLATFORM-HOLDING TANK
126714-05-000

BRACKET-SEAT
16604-01-000 (4)

TANK ASM-HOLDING
(SEE TAB)

PLATFORM-HOLDING TANK
126714-07-000

BRACKET-TIEDOWN, WATER TANK
112628-04-CHT

PLATFORM-HOLDING TANK
126714-15-000
PLYWOOD
860-51-864

ANGLE ASM
131225-01-CHT (M37B)
131225-02-CHT (M39Y)
SCREW
G39-10-12B (6)

VIEW K-K

BRACKET-TIEDOWN, WATER TANK
112628-04-CHT

PLATFORM-HOLDING TANK
126714-16-000

TITLE		99 M37B	
DRAWING NO.		128483	
SHEET NO.		5 OF 5	
DATE		1.6	

