



DANGER

Danger of electrical shock, burns or death. Always remove all power sources before attempting any repair, service or diagnostic work. Power can be present from shore power, generator, inverter or battery. All power sources must be disabled and secured before performing any service.



CAUTION

If you lack the skills, tools or equipment to perform diagnostic or repair work leave such work to an authorized Winnebago Industries dealer or other qualified shop.

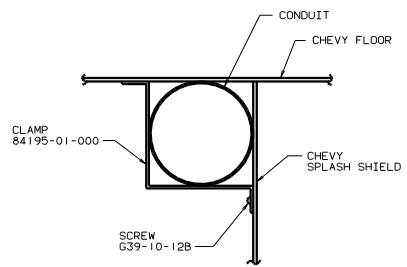

VIEW E-E
(2 PLCS)

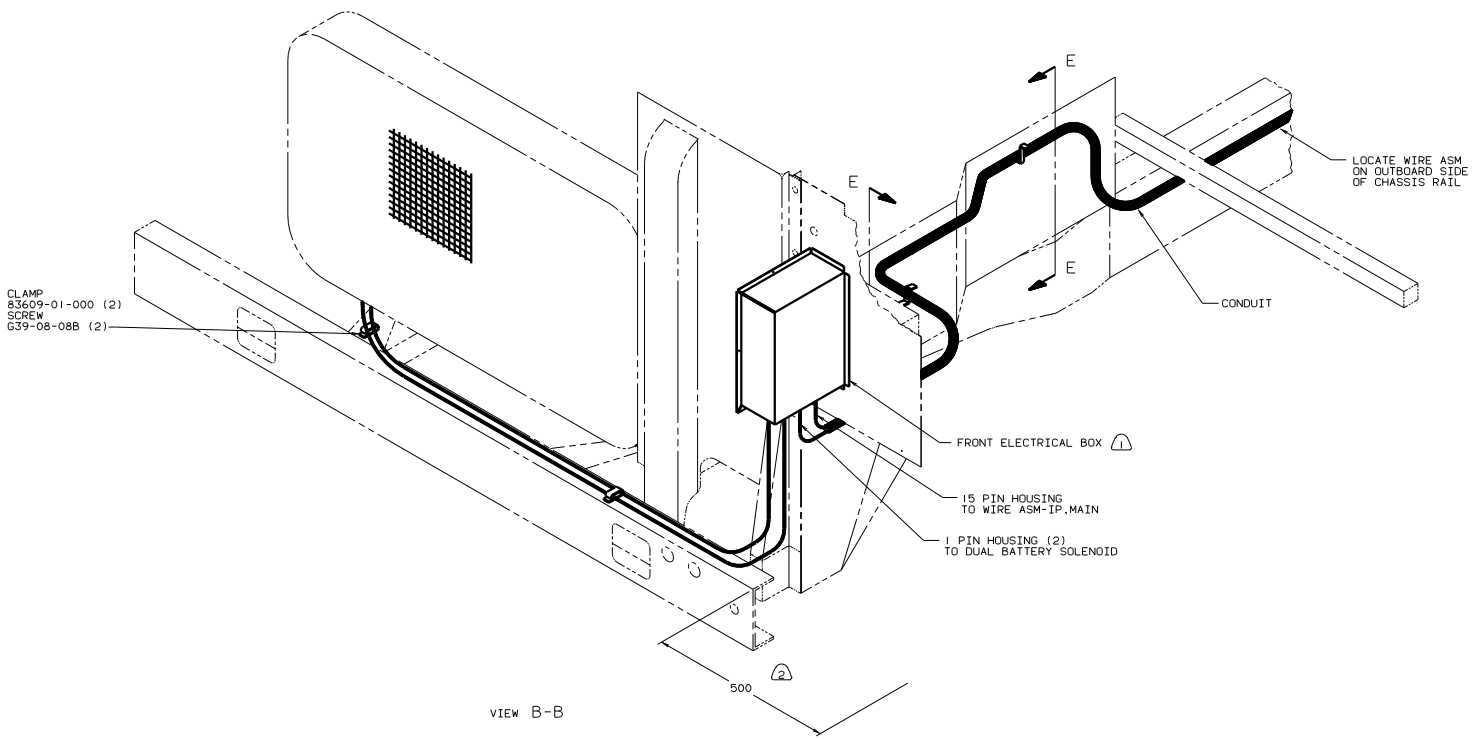

- Ⓜ LAY BATTERY AND GENERATOR CABLES TO THIS DIMENSION TO START INSTALLATION.
- ⚠ SEE WIRING INSTL-FRONT END FOR ADDITIONAL INFORMATION.

NOTES:

97 F25RC

TITLE: WIRING INSTL-CHASSIS	
30 THE SCALE APPLYING TO THIS SHEET	1:1
SHEET 2 OF 2	123875